

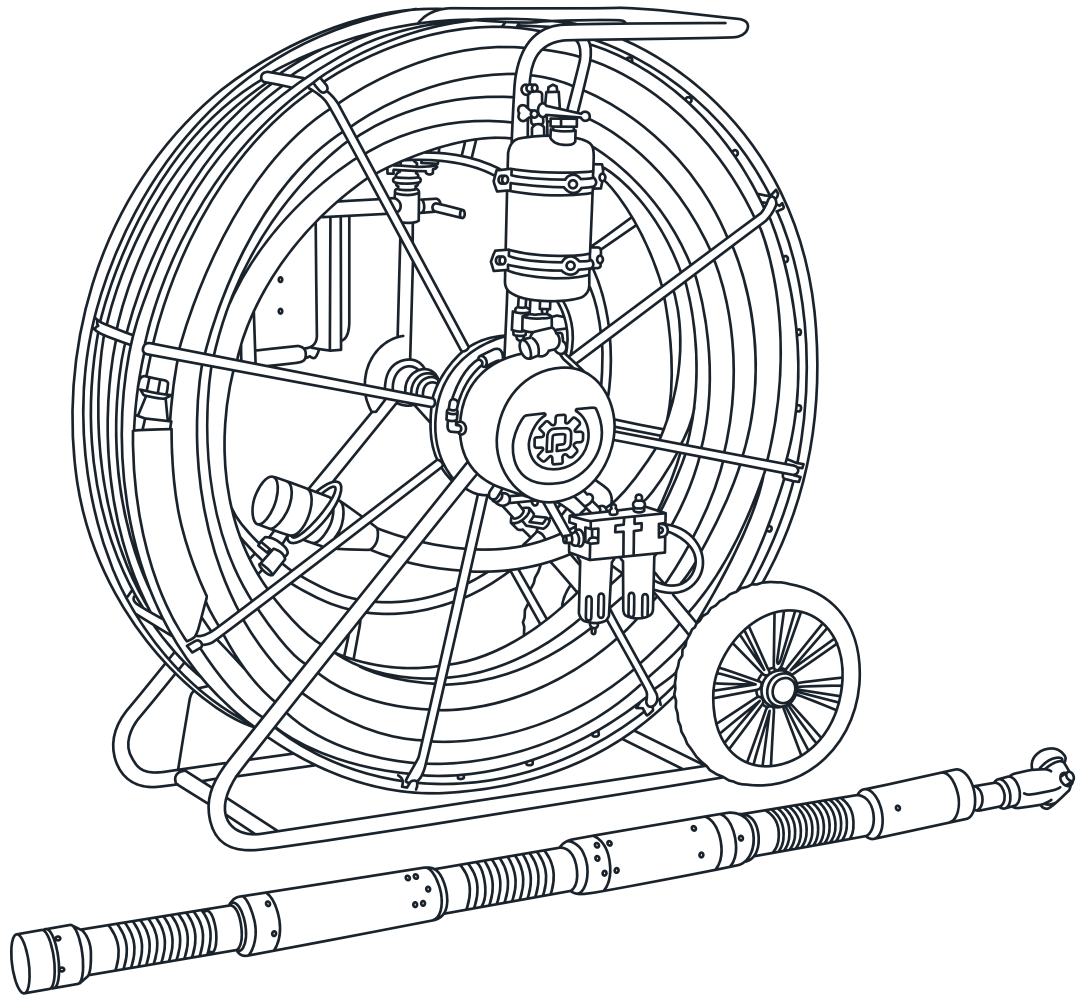

DC MAXI FLEX

Instruction Manual

1.1.2-EU-EN-20260507
80100 >



SCAN ME TO
DISCOVER MORE
INFORMATION
ONLINE



Dancutter A/S, Livøvej 1 A, DK-8800 Viborg, +45 9651 2150, info@dancutter.dk
www.dancutter.com

FIND YOUR DEALER

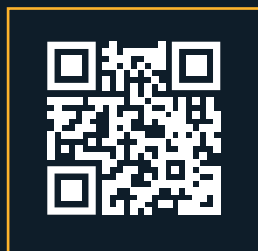

Need support? Scan the QR code
and contact with our recommended Partner

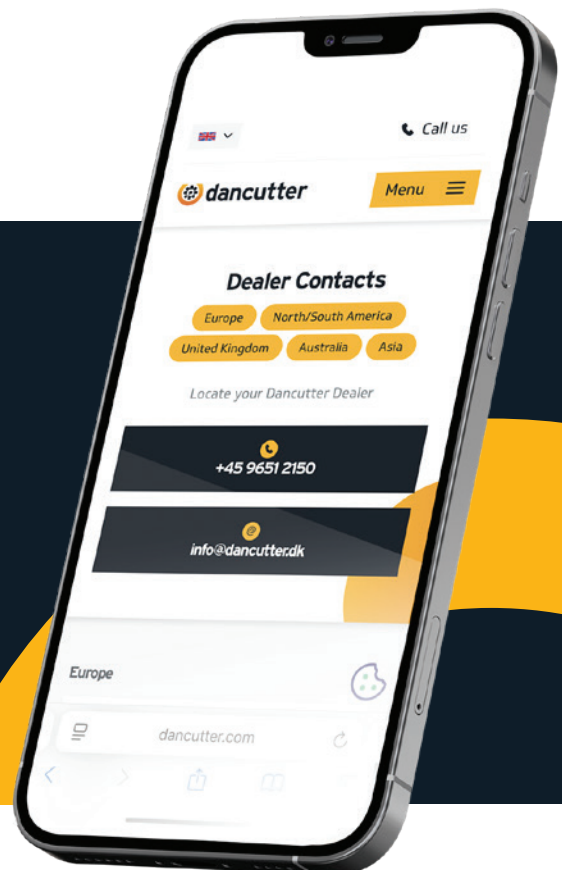

Contents

User Manual, DC MAXI FLEX

Table of Contents	2
1.0 Manufacturer	3
1.1 Distributor	3
1.2 Authorised Representative	3
1.3 WEEE Statement	4
2.0 Model type	5
3.0 Specifications	5
4.0 Safety instructions	5
5.0 Quickguide	6
5.0 Quickguide	7
5.1 Checklist	8
6.0 DC MAXI FLEX	9
7.0 User instructions	11
7.1 Coiler	15
7.1.1 Water separator and oil lubricator	16
7.1.2 Camera cleaner tank	17
7.2 Cutter	18
7.2.1 Attaching the centring tool set for Ø300 mm	19
7.3 Grinder	20
7.3.1 Replacing a grinder	20
7.4 Control unit	21
8.0 Service and maintenance	24
8.1 Grinder	24
8.2 Clean underneath the cover	24
8.3 Clean behind arm/swivel support	25
8.4 Clean the forward/back drive	25
8.5 Clean the rotation function	26
8.6 Maintaining the control unit	26
8.7 Drum shaft	27
8.8 Filter	27
8.9 Service overview	28
9.0 Cutting tools	29
9.1 Tools for cutting PVC and liners	29
9.2 Tools for cutting concrete	30
9.3 Tools for cutting steel	31
9.4 Attachment instructions for cutting tools	32
10.0 Quickguide FPV headset	39
11.0 EU Declaration of Conformity	40

1.0 Manufacturer

Dancutter A/S

Livøvej 1A
DK-8800 Viborg
Tel: +45 9651 2150
info@dancutter.dk
CVR/VAT no.: 26672678

Technical support

If you experience problems with the cutter or if you have any technical questions, please write to **support@dancutter.dk**

Order

If you need spare parts or cutting heads, please write to **order@dancutter.dk**

1.1 Distributor

RSM Lining Supplies Global Ltd.

Coalpit Road,
Denaby Main Industrail Estate,
Doncaster, South Yorkshire,
England, UK,
DN12 4LH

Tel: +44 (0)1709 864 271
sales@rsm-web.com
www.rsm-web.com

Technical support

If you experience problems with the cutter or if you have any technical questions, please write to **sales@rsm-web.com**

Order

If you need spare parts or cutting heads, please write to **sales@rsm-web.com**

1.2 Authorised Representative

Minicam Ltd.

Unit 33, Ravenscraig Rd,
Little Hulton, Salford,
M38 9PU

1.3 WEEE Statement

Under the European Union ("EU") Directive on Waste Electrical and Electronic Equipment, Directive 2002/96/EC, products of "electrical and electronic equipment" cannot be discarded as municipal waste anymore and manufacturers of covered electronic equipment are obligated to take back such products at the end of their useful life. Dancutter will comply with the product take back requirements at the end of life of Dancutter products that are sold into the EU.

For disposal contact Dancutter or the Dancutter partner in your country.



INFORMATION ON DISPOSAL FOR BUSINESS USERS

Your DC SUPER FLEX is marked with the symbol shown above. It means that used electrical and electronic products should not be disposed of in with general household waste. Contact your Local Council who will advise on the correct recycling procedure to follow.

IN THE EUROPEAN UNION

Please contact Dancutter or you nearest Dancutter Service Centre who will inform you about the take-back of the product. You may be charged for the cost arising from take-back and recycling. Small products (and small amounts) might be taken back by your local collection facilities.

For Spain: Please contact the established collection system of your local authority for take-back of your used product.

COUNTRIES OUTSIDE THE EU

If you wish to dispose of your DC SUPER FLEX, please contact your local authorities and ask for the correct method of disposal.

2.0 Model Type

Identification:

System Type: Mobile cutter unit
Model: DC MAXI FLEX, 70 metres

3.0 Specifications

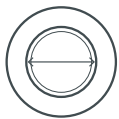

EXTERNAL DIAMETER:

80 mm



WEIGHT:

Cutter: 17,5 kg / Hose reel: 119 kg



HOSE REEL:

L: 1200 mm / W: 750 mm / H: 1220 mm



CUTTER ARM:

Ø: 80 mm / L: 1800 mm



GRINDER:

11000 rpm



AIR SUPPLY:

1100 l/min, (39 cfm)



SUPPLY HOSE:

70 m



AIR PRESSURE:

max 10 bar - 145 psi



POWER SUPPLY:

110/240 VAC - LN 



Stainless steel alloy and aluminium

4.0 Safety Instructions

- **NEVER** start the cutter until it is inside the pipeline
- **ALWAYS** switch off the cutter for cleaning
- Disconnect the air supply from the air-processing system before adding washer fluid to a depressurised tank. (7.1.2)
- Visually inspect the cutter. Inspect screws, adapter, cutting tools, etc., on a weekly basis for wear and damage and replace or tighten them if necessary
- If the rack is to be placed on its side, the oil lubricator glass **MUST** be removed (7.1.1)

5.0 Quickguide

**Use an in-/external
compressed air
aftercooler.**

**Maximum water
content per m³
supply air: 20g/m³,
(0,7 ounce/35 cfm)**

**Always ground the
Equipment. **

Congratulations on your new DC MAXI FLEX

To get the most satisfaction from your cutter, it is important that you spend sometime learning how to operate and maintain it.

Use an in-/external compressed air aftercooler.
Maximum water content per m³ supply air:
20g/m³, (0,7 ounce/35 cfm)



AIR REQUIREMENT

1100 l/min, (39 cfm)



POWER SUPPLY

110/240 VAC - LN 



AIR PREASSURE

max 10 bar - 145 psi

Forcing a 45° bend

(Applies from Ø150 mm)

- Turn the cutter in the same direction as the bend
- Raise the cutter arm
- Push the cutter through
- Lower the cutter arm
- In the case of several bends, make a note and put tape on the hose, so you know which way it shall face

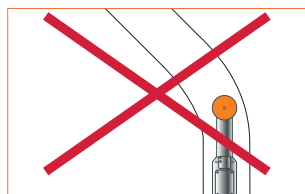
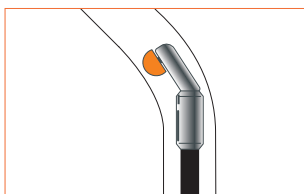

As needed

- Lubricate the drum shaft with grease in the grease nipple
- Check the air filter (part number P57106) in the water separator to be kept clean and changed as needed

Before use

- Check that there is oil in the lubricating unit
- **NEVER** bend the cutter outside of the pipe
- The cutter operator is responsible for ensuring that the cutter is handled safely, in and outside the pipe
- The forward section must **ALWAYS** be closed together during transport in and outside the pipe
- Only use **PURE AIR - WASHER FLUID W/ALCOHOL** in the container for camera cleaning



Check the oil



Completely close the forward/back drive

After use

- Clean the outside of the cutter with a water hose (not a high-pressure cleaner) or compressed air
- Clean the forward/back drive with compressed air Fully extend the unit and clean it in traces and edges with paper and cloth.
- Raise the arm all the way and clean the hollow space behind the tilt unit using compressed air. Next, lubricate the piston with oil and re-lower the arm
- Remove the grinder and drip oil into the clutch nipple, then blow it with a compressed air gun to ensure the oil is properly distributed throughout the engine, preventing any potential water or moisture ingress

Lubricate the grinder



Lubricate the piston

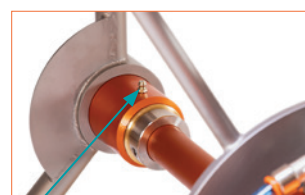
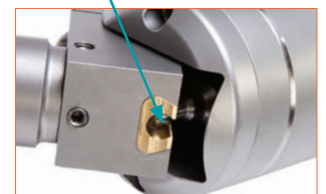

Grease in the grease nipple



Air filter

5.1 Checklist

AIR

1. Connect an air supply to the air-processing system - max 10 bar and 1100 l/min.
2. A refrigeration dryer must be used with the compressor.
3. Maximum moisture content per m³ of supply air: 20 g/m³.



OIL

1. Add pneumatic oil.
2. Check that the oil is clean and that its colour is clear. Change the oil if it becomes cloudy.
3. Adjust the adjustment screw once the grinder has been started. One drop of oil should come out every 8–10 sec.
4. Once the grinder has started, it should be possible to see an oil film flow into the 10 mm hose.



If the system has to be laid down during transport, unscrew the oil-lubricator glass to prevent oil from entering the cleaner tank.

CAMERA CLEANER

1. Clean the camera using either pure air or washer fluid w/alcohol. It is important that whatever fluid is used can evaporate from the camera lens.
2. When adding liquid to the tank, the system/tank must be de-pressurised.



RAISING/LOWERING THE ARM

1. It is possible to regulate the speed of the arm by rotating the needle valve; the adjustment works only in the 'UP' position. The arm will lower under its own power. Adjust the arm so that it rises a bit slower than it falls.



FORWARD/BACK DRIVE

1. Use the forward/back drive only when cutting.
2. The forward/back drive must **ALWAYS** be retracted to a closed position during transport, in a tube and outside a tube.



6.0 DC MAXI FLEX

Dancutter's Most Powerful Cutter

DC MAXI FLEX is Dancutter's most powerful cutter. It has an extremely powerful grinder which makes the cutter both fast and efficient. The DC MAXI FLEX is flexible and can go through several 45° bends in a 150 mm / 6" pipe and works effortlessly whether the pipe is straight or has bends.

If you are mostly working in larger pipes, DC MAXI FLEX is your right choice for reopening laterals or removing hard deposits like concrete.

When you are cutting, milling, and grinding in pipes from 150 - 400 mm / 4" - 16", DC MAXI FLEX is a powerful solution whether the pipe is made of PVC, concrete, cast iron, or steel.

We also offer an extensive range of cutting heads for various purposes.

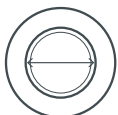
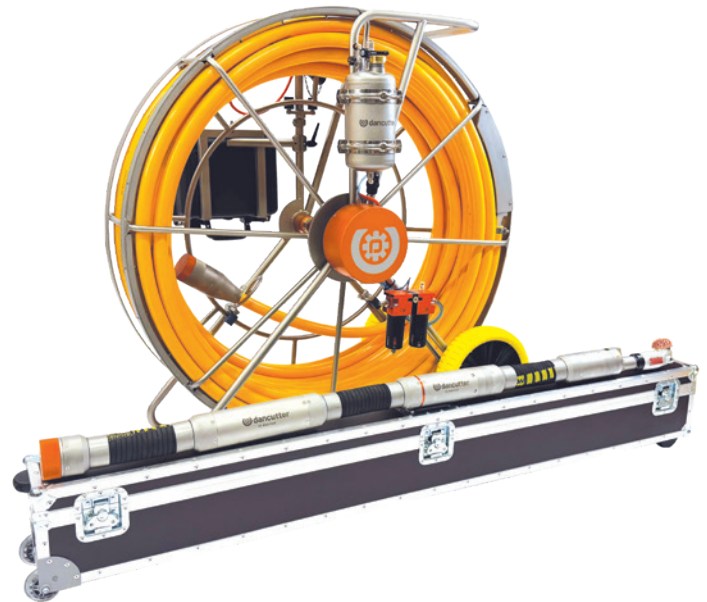

PIPE DIMENSION

Dia. 150 - up to 400 mm, 4" - 16"
(with centring tool set)



SUPPLY HOSE

70 metres, 230 ft



FLEXIBLE

45° in 150 mm, 6" pipe



EXPANSION / CONTRACTION

150 mm - 6"



ROTATION

360° continuously



GRINDS, MILLS AND CUTTES

Pvc, liner, concrete, iron, stainless steel

Technical support

If you experience problems with the cutter or if you have any technical questions, please write to support@dancutter.dk

Order

If you need spare parts or cutting heads, please write to order@dancutter.dk



Highlights

Extremely powerful grinder

360°-degree continuous rotation

High-quality stainless-steel alloy

12" colour display

Flexible through several 45° bends

Cuts, grinds, and mills in all materials

User friendly

Precise control

Toolbox, centring tool, and transport box are standard accessories

Technical data

Pipe diameter: 100 - up to 400 mm / 4" - 16" (with centring tool set)

DC MAXI FLEX can be operated by just one person using the control unit

Control unit with 2 joysticks, and keypad with a 12" colour display. It features inlet and outlet sockets for connecting a video recorder, computer, external camera, or FPV headset

The camera on the cutter has a spray nozzle that cleans the lens with air or washer fluid

The DC MAXI FLEX comes with a 70-metre hose



AIR SUPPLY

1100 l/min, 39 cfm



GRINDER

11000 rpm



AIR PRESSURE

Max 10 bar, 145 psi



POWER SUPPLY

110 / 240 VAC - LN 



WEIGHT

Cutter: 17,5 kg / Hose reel: 119 kg



STAINLESS - STEEL FRAME

L: 1200 MM / W: 750 mm / H: 1220 mm
L: 47.24" / W: 29.52" / H: 48"

Standard and extra accessories for DC MAXI FLEX

We offer a versatile range of accessories and spare parts for your Dancutter solutions.

Get an overview on www.dancutter.com

7.0 User instructions

Place the hose reel where the work is to be done.
Connect the accompanying supply cable to 110/230 VAC
and to the control unit's outlet.

Similarly, connect the orange signal cable on the hose reel
to the control unit.



Make sure that both tank ball valves are closed.

CLOSED



Now, connect compressed air from the
compressor to the reel's combination water
separator/oil lubrication unit. (7.1.1: "3").



We advise having a refrigerated dryer mounted on the
compressor at all times to minimise moisture content so
it never exceeds 20 g/m³.



Feed the plug on the yellow hose through the ring on the reel, pull out a short section of hose and lay it on the ground.



Lay the cutter in continuation of the yellow hose and unscrew the two orange caps. Push the two ends together and screw the coupling on the hose section tightly against the cutter.

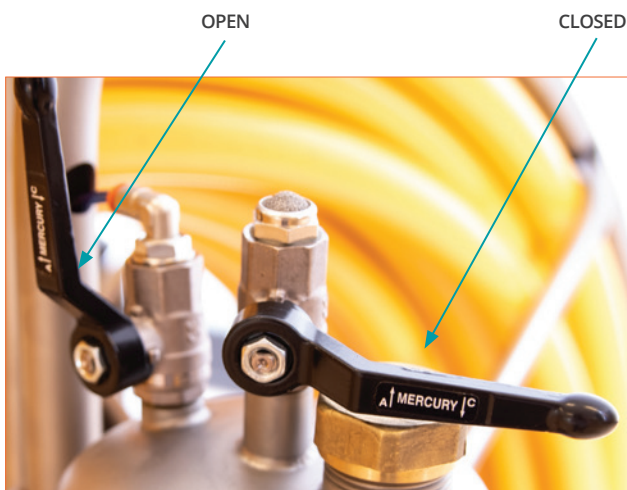

Now open the ball valves supplying air to the tank.



Open the lid of the control unit and loosen the emergency stop button. Turn on the camera light, if necessary.

The cutter is now ready for use

Now feed the cutter into the pipeline where it will work. If the cutter needs to pass through bends to reach the work site, follow the feeding process on the monitor/control unit so it is possible to lift/swivel the cutter arm when it reaches the bend, which eases the lead-in process.

Remember to re-lower the cutter arm after it has passed through the bend.

Switch on the cutter on the control unit and let it run for a while before starting the task; slowly lift the grinder by pulling the joystick towards you (7.4: "15") so the cutting head hits the work area.

Try the cutter before feeding it into the pipe!

Always ground the Equipment 

For branch line openings, it is important to process a wide area around the branch line opening before the cutting head breaks through the lining or pipe, because doing this will minimise the risk of the cutting head getting stuck. This is done by using the cutter's built-in forward/back drive (7.4: "3") and the rotation function. (7.4: "15")

Reduce pressure on the cutter just before the cutting head breaks through the lining or pipe. The control unit has built-in WiFi for using a FPV headset (useful in bright sunshine).

Connect an extension cable (available in lengths of 6 and 15 metres) between the reel and the control unit .

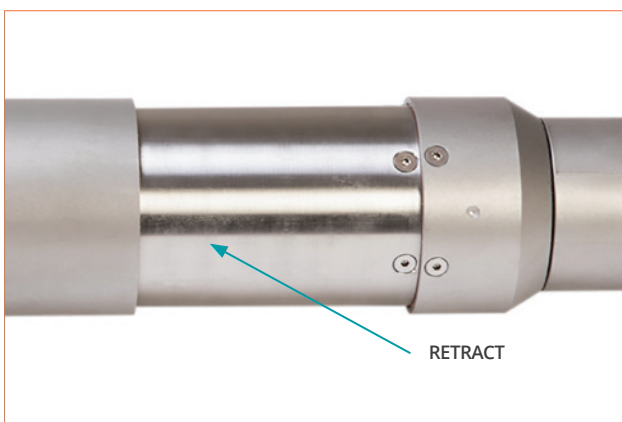

ALWAYS retract the forward/back drive section before moving from one position to another in a pipeline. (7.4: "3")

After completing a task, refer to the service and maintenance instructions in section 8.0.

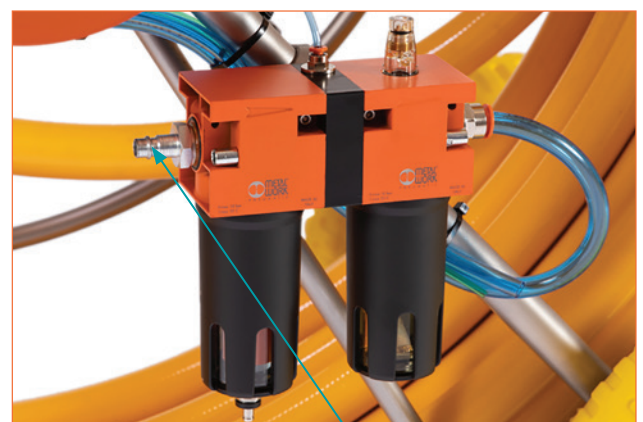

Disconnect the air supply.

REMOVE SUPPLY HOSE



Make sure the tank is depressurised.

POSITION BALL VALVES AS SHOWN

CLOSED



Disconnect the cutter from the yellow supply hose. It is important to reattach the caps for cutter and hose to keep out dirt.

Put the cutter back in the transport box.



Disconnect the two plugs on the back of the control unit and screw on the caps on the cables and control unit.



Close the control unit and hang it back on the reel



7.1 Reel (Coiler)

1. Filling spout for washer fluid
2. Camera cleaner tank
3. Cover for sluice and slip ring
4. Air processing system

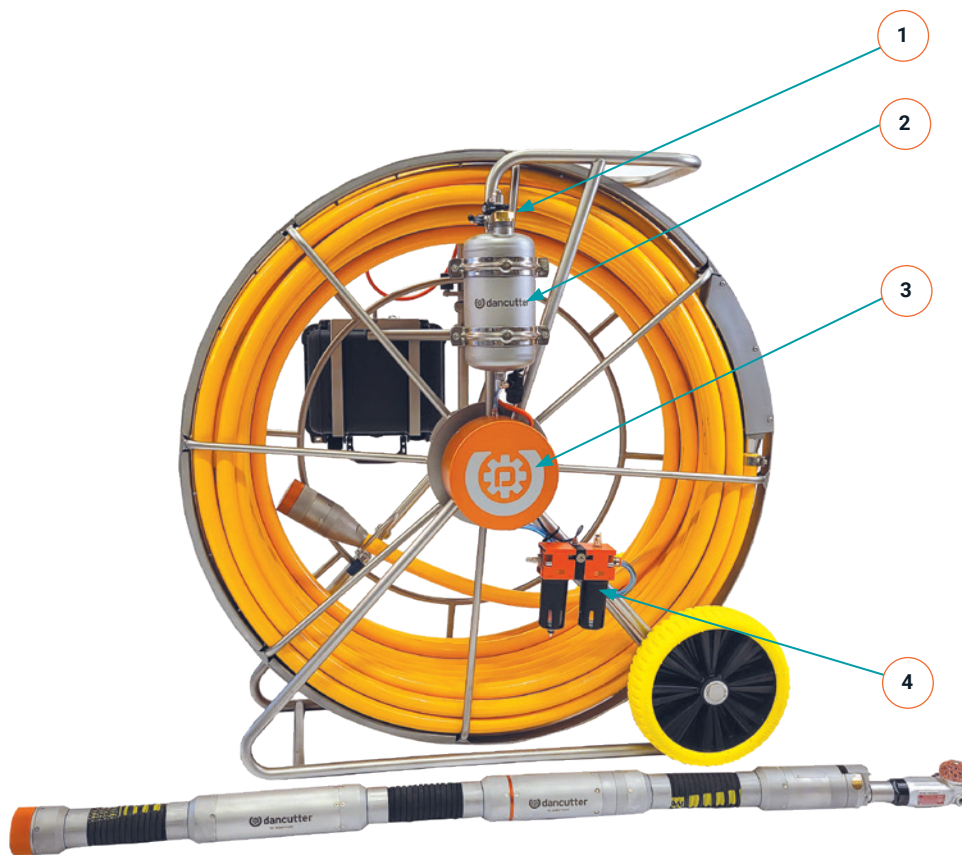

7.1.1 Water separator and oil lubricator

Add oil in depressurised condition before using the cutter. Remember to fill with oil when the top of the oil is visible in the glass (8). It is important that the glass never runs out of oil, as this will damage the cutter and substantially reduce its efficiency.

Use pneumatic oil only (**item no.: DCHY29307**).

Keep the air filter (**item no. P57106**) in the water separator (4) clean and replace as needed. Air supply problems can be resolved by replacing the air filter.

This is done by unscrewing the black bottle and replacing the filter (depressurise the cutter first).

It must be possible to look in the liquid indicator on the oil lubricator (where the adjusting screw (5) is attached) and see a drop of oil appear every 8–10 seconds after the cutter starts. If this doesn't happen, adjust the top screw.

If the unit has to be laid down during transport, unscrew the oil tank (8) so oil is not admixed in the air processing system, as it can be mixed around in the air outlet (1) for the tank.



1. Air outlet for camera cleaner tank
2. Automatic water separator with air filter cartridge (**item no. P57106**)
3. Air inlet from compressor
4. Automatic water separator
5. Adjusting screw for oil lubricator (preset at the factory)

6. Air outlet for sluice/cutter
7. Automatic oil lubricator
8. Oil tank (remember to fill with pneumatic oil, **item no. DCHY29307**)

7.1.2 Camera cleaner tank

Working in a pipeline can dirty the cutter camera, impairing the quality of the images on the control unit monitor or FPV headset and making the work more difficult.

The cutter is equipped with a spray nozzle, which makes it easy to clean the camera while working.

REMEMBER to add washer fluid before using the cutter if you want to use fluid to clean the camera. It is also beneficial to just use dry air.

“Empty tank for a dry task” – “Wet tank for a wet task”.

IMPORTANT!

Disconnect the supply air from the air processing system and depressurise the tank before adding washer fluid.

This is why it is **IMPORTANT** to correctly position the two ball valves for the camera cleaner tank.

The illustration below shows how the two ball valves must be positioned for operating and for adding washer fluid.

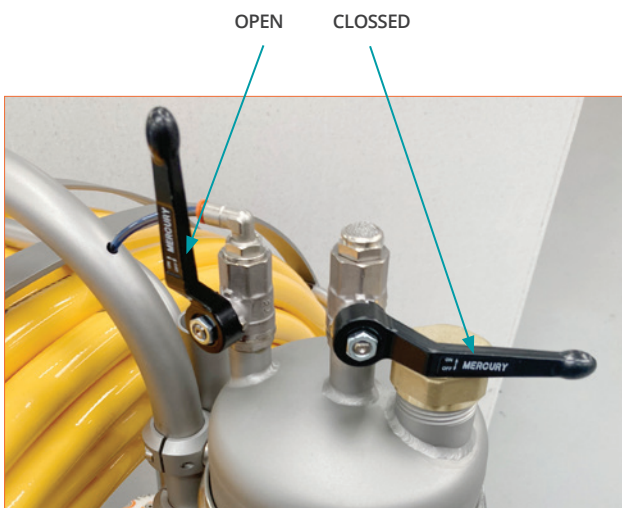

Position for operating the cutter

Before starting to work, set the two ball valves so that the supply of air to the tank is opened and the ventilation is closed.



Position for adding washer fluid

Set the ball valves in the opposite positions. Close the valve supplying the tank with compressed air and open the valve for venting the tank. Completely empty the tank of air before dismantling the brass lid (using a suitable tool). Then add washer fluid.

7.2 Cutter

1. Camera
2. Camera spray nozzle
3. Forward/back drive section
4. Screws for grinder attachment
5. Rotation section: 360° rotation
6. Complete intermidiate hose

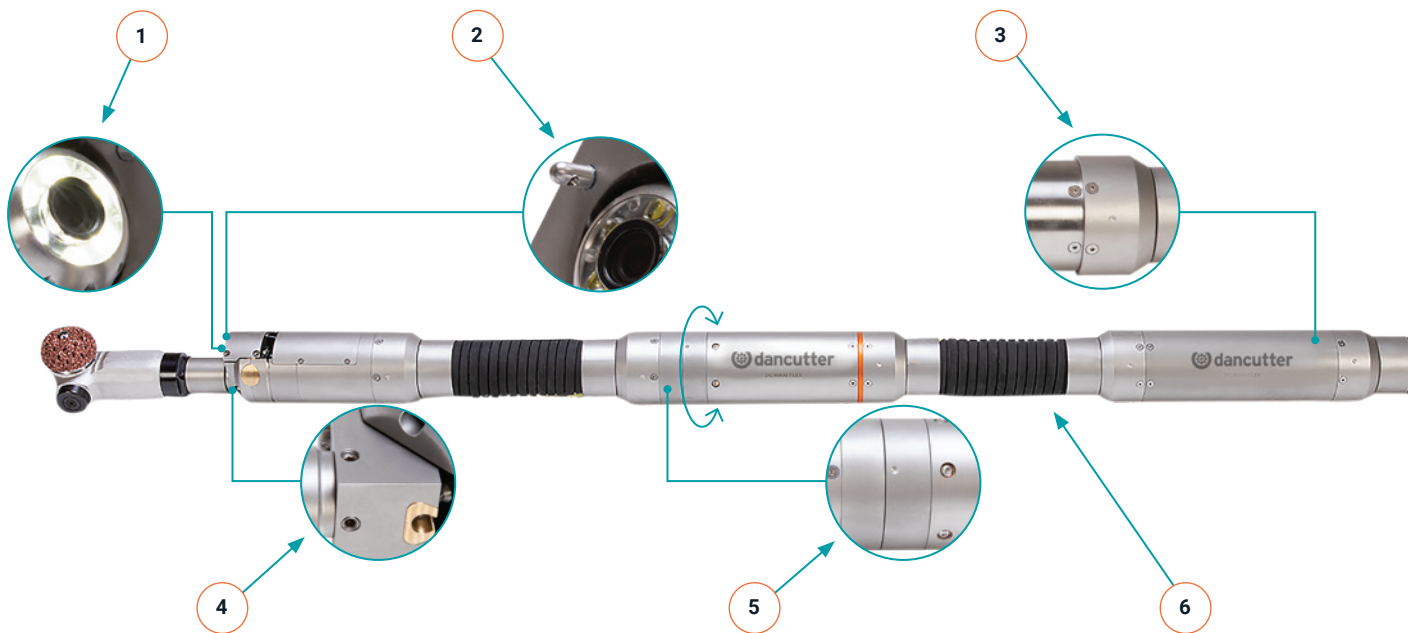

Specifications

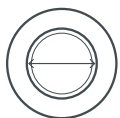

PIPE DIMENSION

Dia. 150 - 300 mm, 4" - 16"
(400 mm with accessories only)



SUPPLY HOSE

70 metres, 230 ft



FLEXIBLE

45° in a 150 mm, 6" pipe



EXPANSION/ CONTRACTION

150 mm, 6"



ROTATION

360° continuously



GRINDS, MILLS AND CUTTES

Pvc, liner, concrete, iron, cast iron,
stainless steel

7.2.1 Attaching the centring tool set

Guide the set of centring tools onto the cutter from the back end. Guide the individual rings into their positions and fasten to the various sections.

1. Set of centring tools on their holder
2. The cutter with the set of centring tools attached to different sections

NOTE!

Only one of the five centring rings is equipped with a grease nipple. Attach this to the front of the cutter against the Grinder, between the accompanying retainer cone and clamp ring.

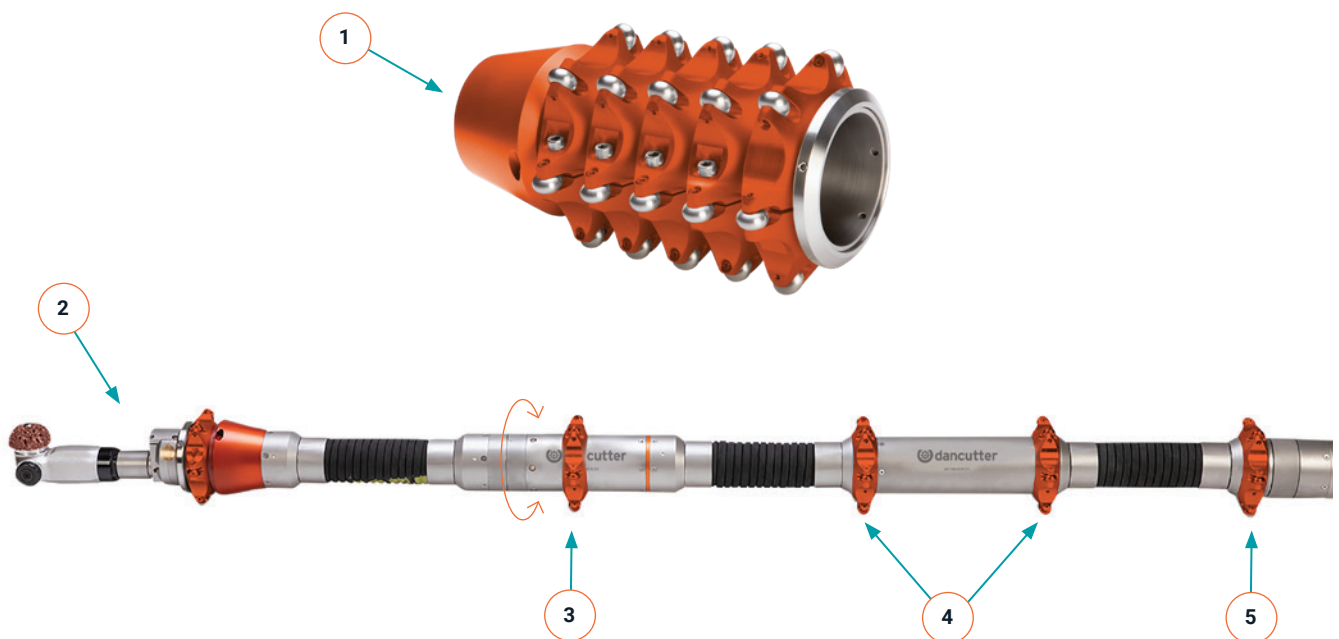

ATTACHING THE SET OF CENTRING TOOLS

3. Attach behind the rotation section and NOT on the rotation section
4. Attach CLEAR of the forward/back drive
5. Attach to the last section

7.3 Grinder

The cutter comes with a hose reelard grinder. Dancutter provides various other types of grinder, however, for different purposes and with different properties. These are illustrated below.



Grinder: hose reelard, attached
Powerful motor covering most tasks:
Applies from Ø150–400 mm pipes
(400 mm with accessories only)



Grinder: hose reelard, attached
Ø100–400 mm pipes
(400 mm with accessories only)



Grinder: hose reelard, attached
Axial Grinder, Ø100–400 mm pipes
(400 mm with accessories only)

7.3.1 Replacing a Grinder

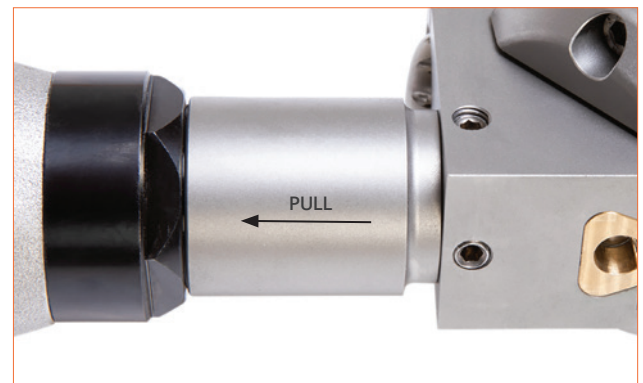

1. Loosen the three screws with the hex key
2. The grinder can then be pulled out
3. Install a new grinder in the reverse order. Moisten the O-ring with oil before pushing in the grinder.
If the O-ring is cracked or broken, replace it. Visually inspect it
4. Add a little pneumatic oil in the detached grinder and thoroughly blow it with an air gun to spread the oil inside it before putting the grinder back in the toolbox

7.4 DC Control Unit 2.0

With the DC Control Unit 2.0 you can control your DC SUPER FLEX and DC MAXI FLEX. Attach the cable from the coiler and the power cable to the control unit and it will power up. Please protect your control unit from water as it is not waterproof when open. The following will describe the function of each button/joystick on the control unit.

- | | | |
|--------------------------|--|----------------------------|
| 1. Stop | 6. Video in | 11. Reverse Rotation |
| 2. Grinder | 7. Video Out | 12. Rotation Speed |
| 3. Left joystick | 8. Reverse Forward/Backward | 13. Playback Control Panel |
| 4. Camera clean | 9. USB Memory Stick/Charge FPV Headset | 14. Start Recording |
| 5. External video source | 10. Light | 15. Right Joystick |
| | | 16. Stop Recording |

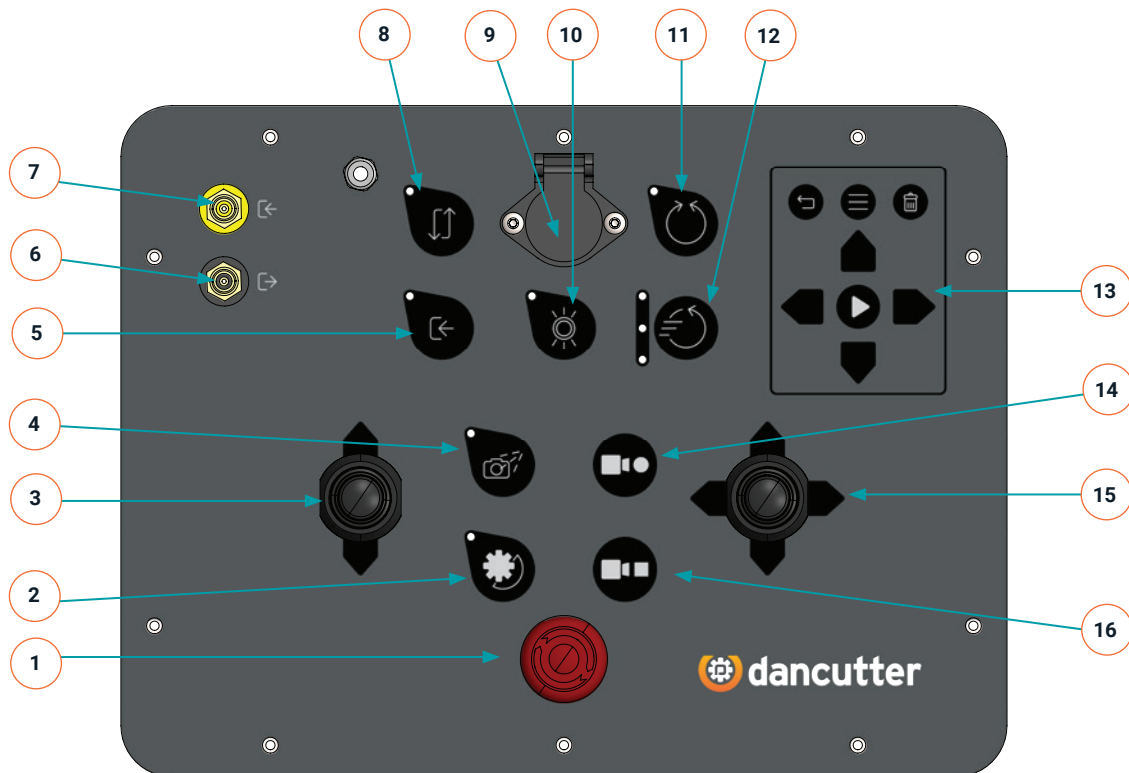

Specifications



DISPLAY
12"



LENGHT
L: 350 - B: 300 - H: 150 mm



WEIGHT
7 kg, 15.4 lb



GRINDER: Press to start and stop the grinder. The grinder is on when the green light is on.



STOP: To halt all movement of the cutter, press this button. To return to the normal operating state, rotate the button. It is important to note that even after releasing the stop button, the grinder will remain inactive.



CAMERA CLEAN: To clean the camera lens, press the button briefly to dispense a small amount of sprinkler fluid or air. Alternatively, press and hold the button for 3 seconds to activate the sprinkler, which will remain on until the button is pressed again. You will know the camera cleaning function is active when the green light is on.



LIGHT: Press to turn the camera light on and off. The camera light is on when the green light is on.



LEFT JOYSTICK: Use this to operate the cutters forward/backward movement. How far the forward/backward section is extended is shown on the bar at the bottom of the screen.



RIGHT JOYSTICK: Use the up/down to raise and lower the grinder on the cutter. Use the right/left to rotate the cutter.



ROTATION SPEED: Press this button to adjust the rotation speed of the cutter in three levels. 1 light on: low speed. 2 lights on: medium speed. 3 lights on: high speed.



START RECORDING: Press to begin recording a video. It's important to ensure that a USB stick has been properly inserted into the corresponding USB socket, as the recording will be automatically saved to the stick. You will know that the control unit is recording when the "REC" indicator blinks in the lower left corner of the screen.



STOP RECORDING: Press to stop the recording.



PLAY: While in normal mode, press the PLAY button to take a snapshot of the screen. The snapshot is saved directly onto the USB stick. When you take a snapshot "SNAP" is displayed briefly on the screen.



EXTERNAL VIDEO SOURCE: Press this button to switch between video sources on the screen. When the light is off, the video feed is sourced from the camera built into the cutter. Conversely, when the light is on, the video feed is sourced from an external video source that has been connected to the "video in" socket on the control unit. Note, the settings for "reverse forward/backward" and "reverse rotation" are saved independently for each video source, and will automatically switch back to their saved state when the video source is changed back.



← **VIDEO IN:** Use this if you want to display video from an external source on the control unit's screen.



→ **VIDEO OUT:** Use this if you want to display the video from the cutter on another screen.



REVERSE FORWARD/BACKWARD: Press this button to reverse the direction of the cutter's forward/backward movement when using the joystick. This feature is particularly useful when an external camera is being used to view the cutter from a different angle, making it easier and more intuitive to control. Note, the light will be illuminated when the forward/backward movement is reversed, indicating that the feature is currently active.



REVERSE ROTATION: Press this button to reverse the direction of the cutter's rotation when using the joystick. This feature is particularly useful when an external camera is being used to view the cutter from a different angle, as it can make controlling the cutter feel more intuitive and natural. Note, it's worth noting that the light will be illuminated when the rotation direction is reversed, indicating that the feature is currently active.



PLAYBACK CONTROL PANEL: This panel is used to control the playback function. You can playback videos and snapshots recorded with the control unit.



MENU: Press to enter the playback menu.



RETURN: Press to go back or to exit the playback menu.



DELETE: Press to delete video recordings or snapshots.



PLAY: Press to play/pause videos or to enter menus and folders.



ARROWS: Use to navigate through menus, folders and files.

8.0 Service and maintenance

8.1 Grinder

- Clean the grinder with water or compressed air.
- Unscrew the hex screw in the end of the Grinder (**GRS**), add a drop of grease to the screw hole and re-attach the screw. Once a week or as needed.
- After operating the grinder in a very damp environment or if it will be idle for an extended period of time, remove the grinder and drip oil into the coupling nipple and evenly distribute the oil in the motor by blowing it with an air gun. This will displace any water/moisture.

GREASE (F85001)



8.2 Clean underneath cover

- Clean with compressed air underneath the cover next to the camera outlet.
- Dismantle the cover if necessary.

DISMANTLE THE COVER



8.3 Clean behind arm/swivel support

- Raise the arm all the way up and clean the space behind the swivel support with compressed air.

Next, lubricate the piston and swivel support, insert with oil and re-lower the arm.



8.4 Clean the forward/back drive

- After cleaning, do **NOT** lubricate the forward/back drive unit with oil or grease, as grime and dirt will stick to it and impede its movement. If the cutter gets scratched and becomes leaky, water will be able to penetrate the section from the outside. Therefore, keep this section **CLOSE** whenever the cutter is being pushed forward or backwards in the pipeline..

CLEAN WITH COMPRESSED AIR AND
DRY WITH PAPER AND CLOTH

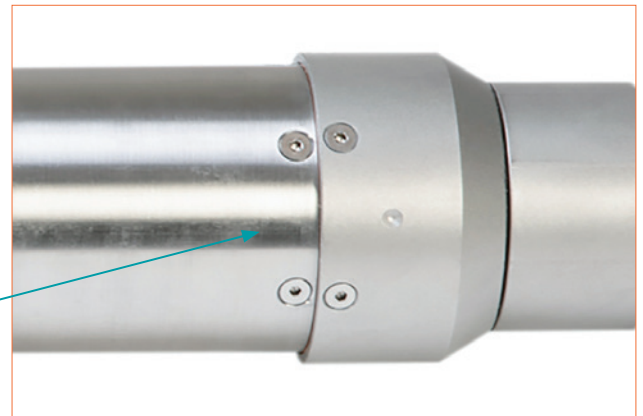

8.5 Clean the rotation function

- Remove sand and dirt by blowing compressed air into the thin groove.
- Continuing to use the rotation function if this groove is dirty will needlessly overload the rotation motor. It can also cause a defect in the rotation motor or damage components in the control unit.

CLEAN THE GROOVE WITH
COMPRESSED AIR

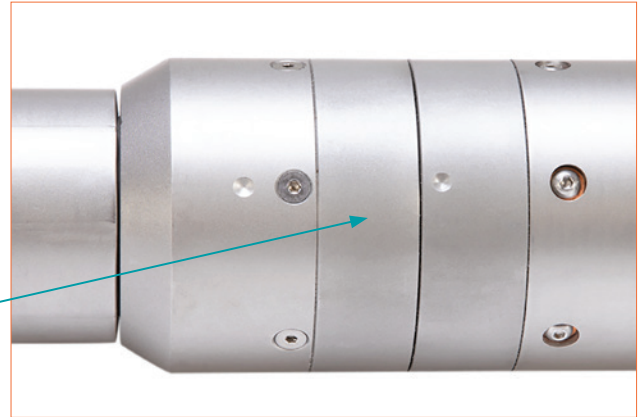

8.6 Maintaining the control unit

- Avoid getting water/moisture on the control unit, as it is not watertight. Close it after use and hang it on the hose reel to protect the screen and switches.
- Always replace caps on **CABLES AND CONTROL UNIT** after use to protect the power outlets.
- Always hang the control unit in place after use.

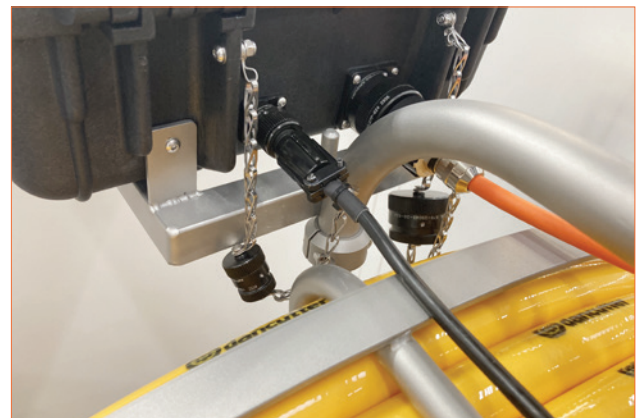

8.7 Drum shaft

- Lubricate the drum shaft with grease in the grease nipple. If used daily, do this roughly twice a year.

GREASE

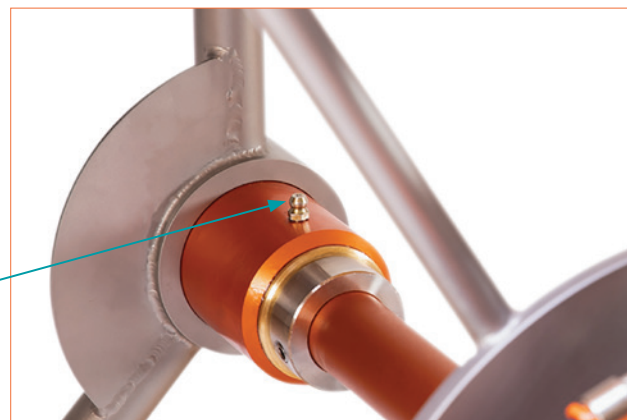

8.8 Filter

- Clean the water-filter insert as needed. (F80546)

FILTER



8.9 Service overview

SERVICE OVERVIEW			
Part - components - service	Daily	Weekly	Other
Cleaning the cutter.	x		
Check pneumatic oil. See 7.1.1 (5). Add oil as needed. See 7.1.1 (8).	x		
Clean and lubricate the piston and swivel support unit insert. See 8.3.	x		
Lubricate the Grinder. See 8.1.	x	x	
Visually inspect the cutter. Inspect screws, adapter, cutting tools, etc., for wear and damage and replace or tighten them if necessary.	x		
Lubricate with grease in the grease nipple. See 8.7 (once or twice a year)			As required
Add washer fluid. See 7.1.2			As required
Replace air filter. See 7.1.1 (4)			As required
Cleaning the grabber	x		
Lubricate grabber with a drop of pneumatic oil on each arm and move the arms up and down a couple times	x		

9.0 Cutting tools

9.1 Tools for cutting PVC & LINER

The hose reelard cutter is equipped with a grinder which blows air forward to keep dust away from the camera. The cutting tool is replaced using the hex key supplied. It may be necessary to first clean the bolt in the grinder, which secures the cutting head.

Dancutter recommends the use of the following cutting heads for opening a branch pipe in PVC/LINER



DK5025-16 - 50 × 25 mm
PVC/LINER



DJ2550-14 - 25 × 50 mm
PVC/LINER



DK4040-14 - Ø 40 mm
PVC/LINER



DK3045-16 - Ø 32 × 45mm
PVC/LINER



DB8900 - Ø 70 mm
PVC/LINER



DKA1021 - Ø 36 × 41 mm
PVC/LINER

9.2 Tools for cutting CONCRETE

Dancutter recommends using the following diamond heads for concrete.



DD70M8A - Ø 70 mm
CONCRETE



DD75M8 - Ø 75 mm
CONCRETE



DKA1011 - 65 × 30 mm
CONCRETE



DKA1019-16 - Ø 46 × 47mm
CONCRETE

9.3 Tool for cutting STEEL

Dancutter recommends using the following cutting discs for steel.



DD9009 - 76 × 2,1 mm
STEEL



DD9022 - 80 × 27 mm
STEEL



DD9025 - 70 × 10mm,
DD9024 Bolt for cutting disc - STEEL

9.4 Attachment instructions for cutting tools

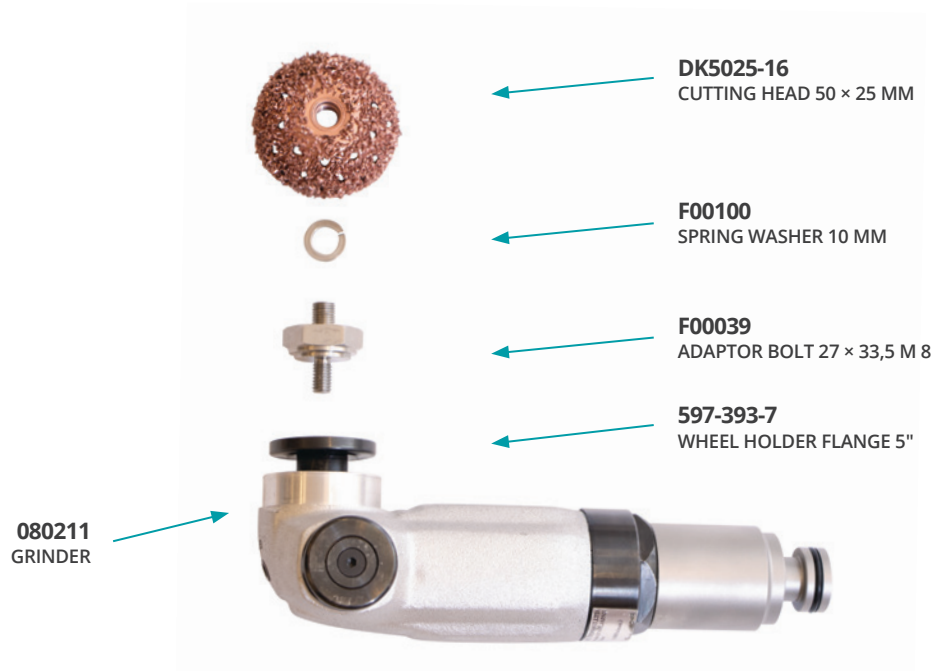
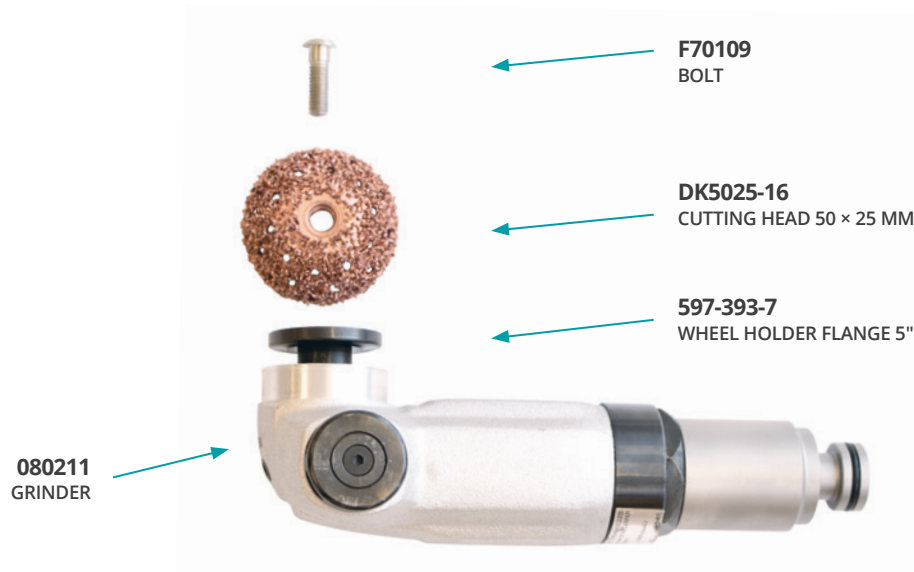

9.4 Attachment instructions for cutting tools

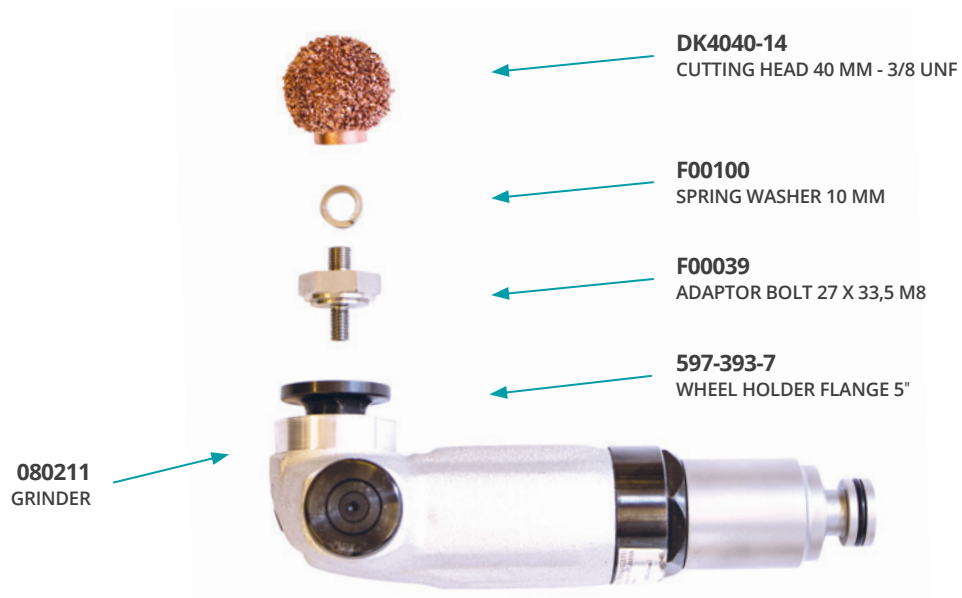
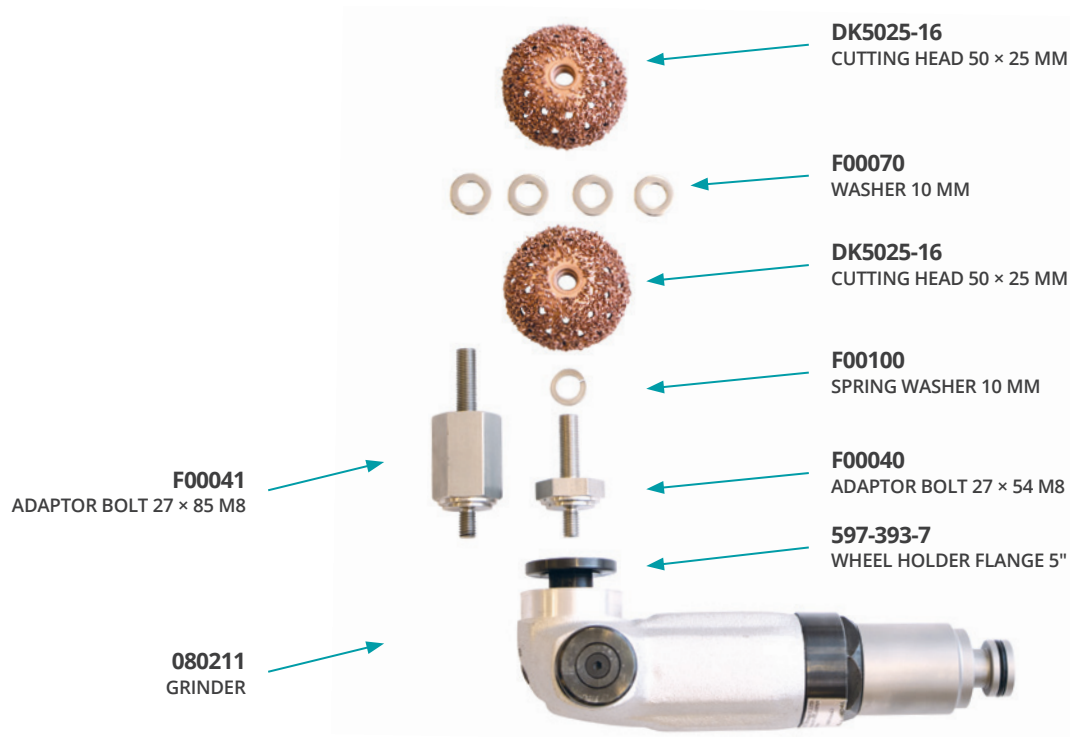

9.4 Attachment instructions for cutting tools

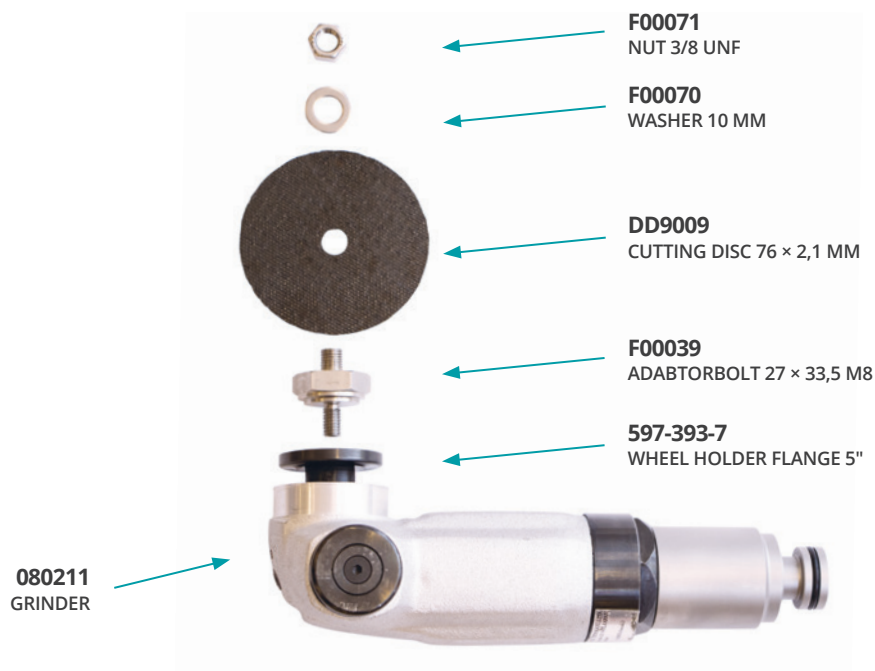
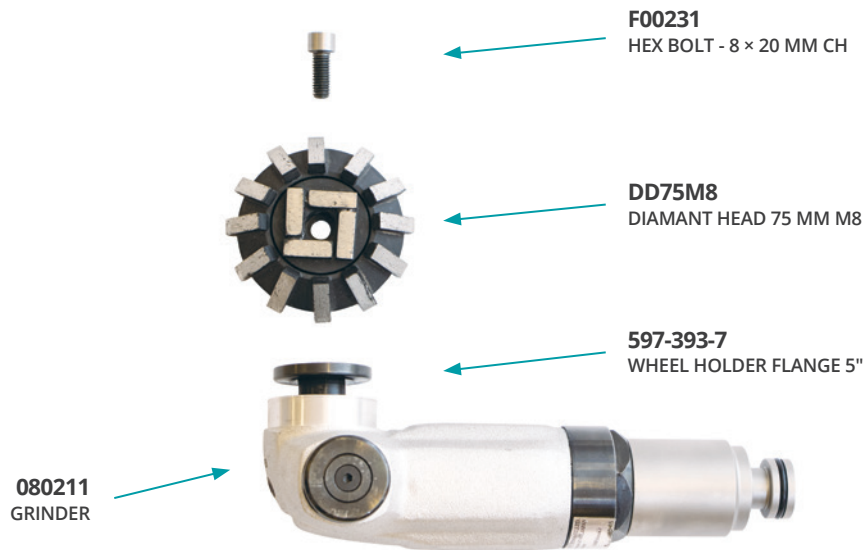

9.4 Attachment instructions for cutting tools

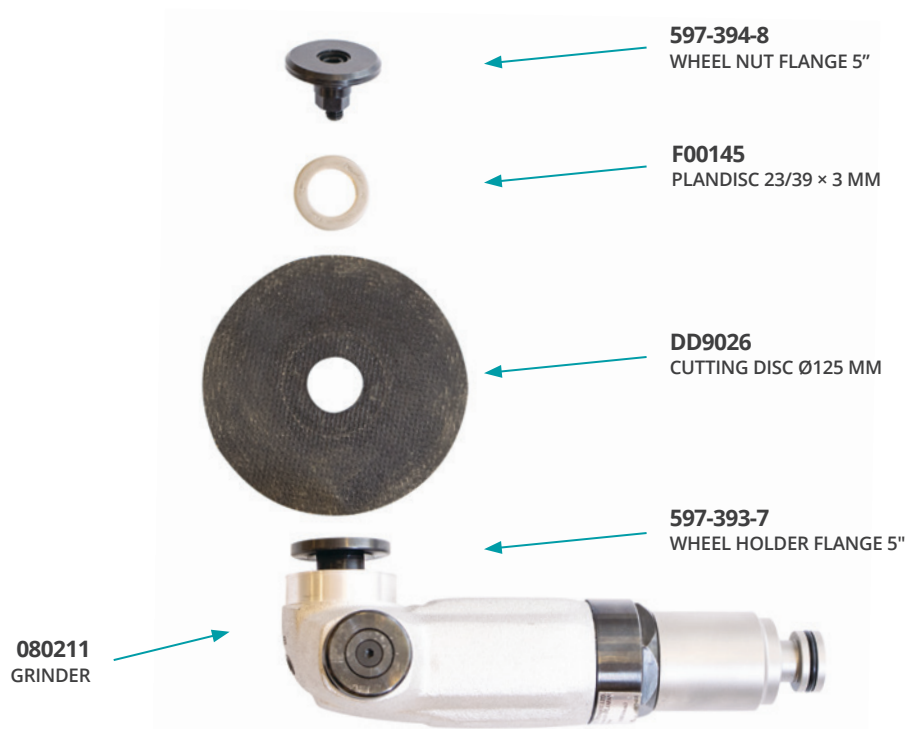
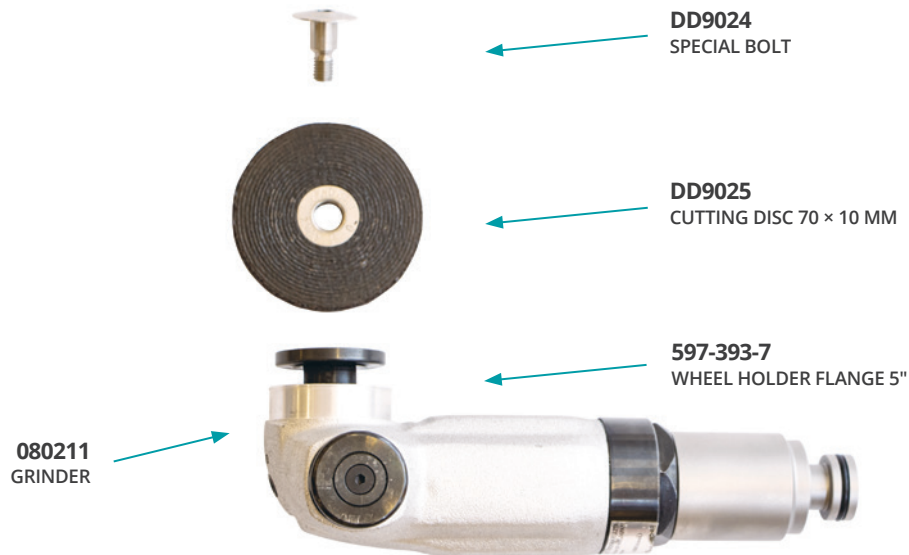

9.4 Attachment instructions for cutting tools

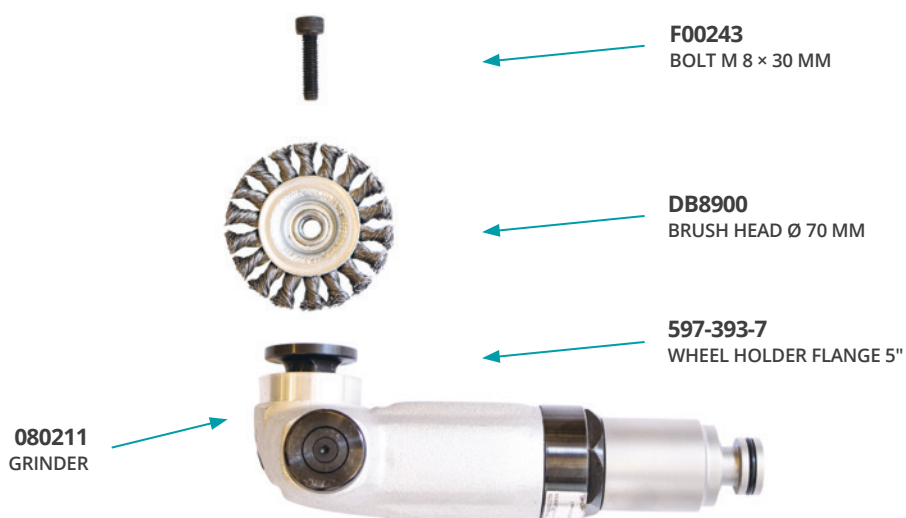
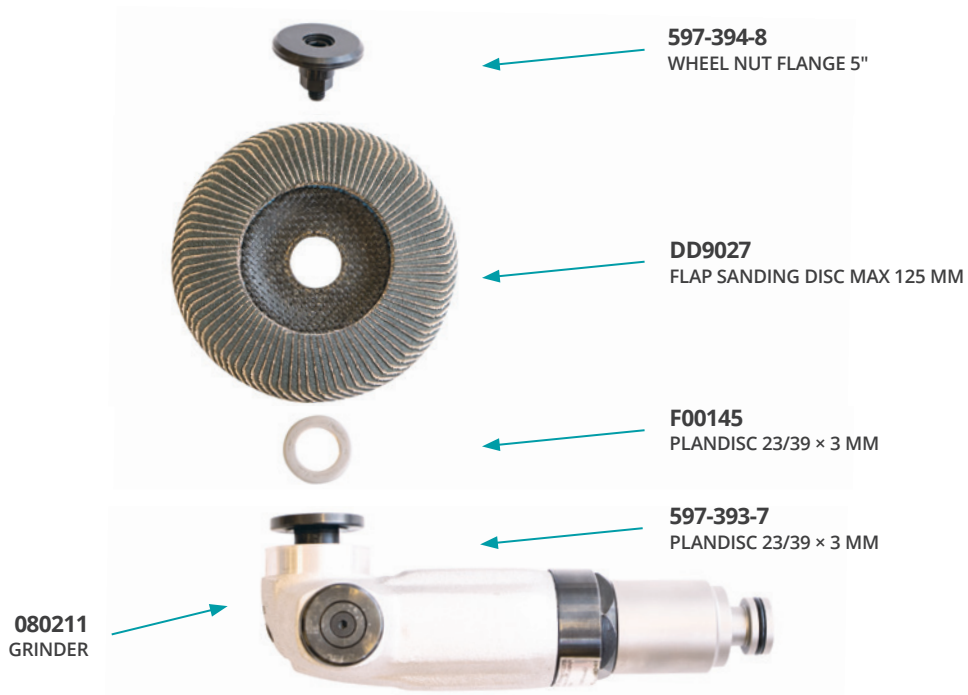

9.4 Attachment instructions for cutting tools

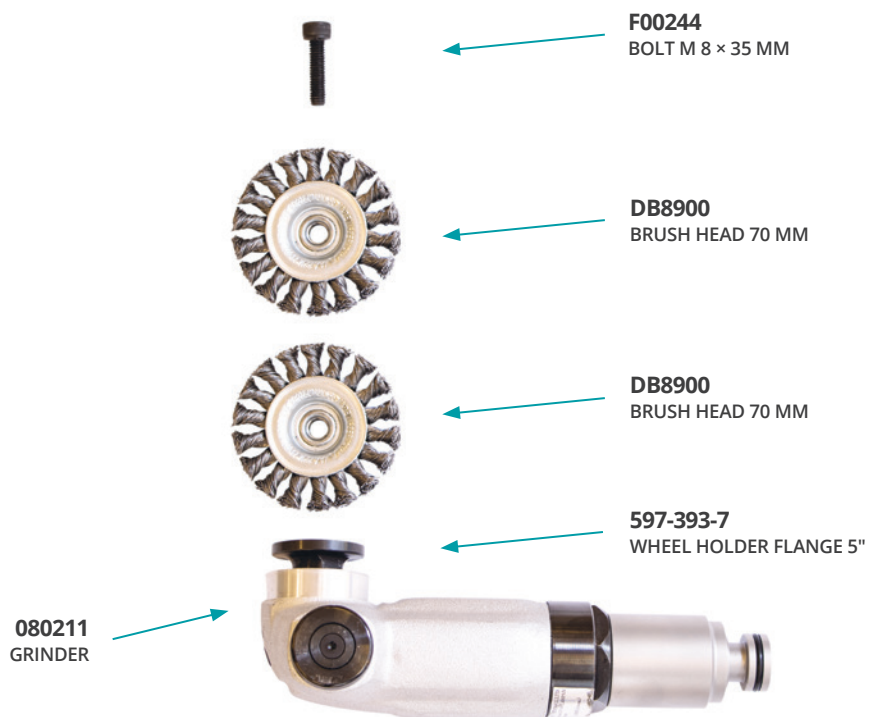

9.4 Attachment instructions for cutting tools

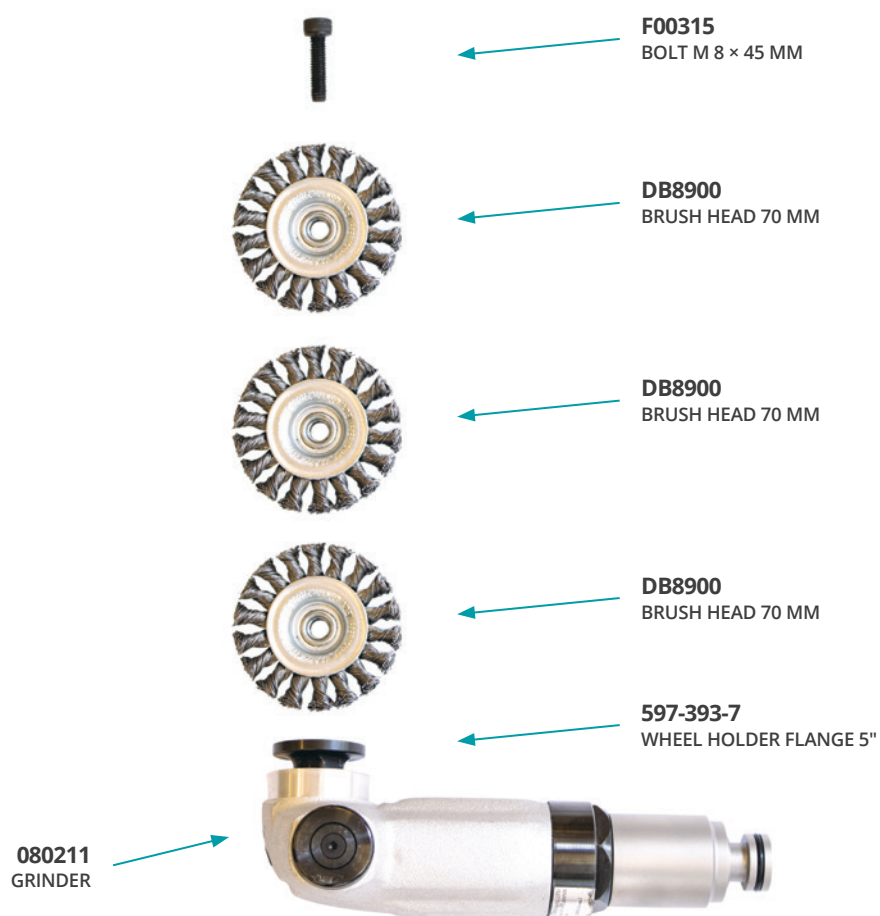

10.0 Quickguide FPV headset

First time setup

- Turn the headset on with the **POWER** button
- Make sure that the control unit on the cutter is turned on
- Press and hold the button **SCAN** for 1-2 seconds while the headset finds the signal from the control unit
- The velcro straps on the headset can be adjusted to fit your size
- To charge the headset battery use the included micro usb cable



11.0 EU - Declaration of Conformity

Object of the declaration:

Product: Cutter equipment
Model/type: DC MAXI FLEX

This declaration is issued under the sole responsibility of the manufacturer.

The object of the declaration described above is in conformity with the relevant Union harmonisation legislation:

Directive 2006/42/EC of the European Parliament and of the Council of 17th Mai 2006
on the approximation of the Laws of the Member States Relating to Machinery.

Council Directive 2014/35/EU on the Harmonization of
The Laws of Member States Relating to Electrical Equipment Designed for
use within Certain Voltage Limits.

Council Directive 2014/30/EU on the Approximation of the
Laws of the Member States Relating to Electromagnetic Compatibility.

Conformity is shown by compliance with the applicable requirements of the following documents.

Reference and date	Title
EN ISO 12100:2011	Safety of machinery - General principles for design - Risk assessment and risk reduction.

Technical documentation is stored at the company address mentioned below:

Signed for and on behalf of: **Dancutter A/S**
Place of issue: DK-8800 Viborg
Name: Simon B. Hoffgaard
Position: General Manager

Signature:





A **Halma** company



Dancutter A/S, Livøvej 1 A, DK-8800 Viborg, +45 9651 2150,
info@dancutter.dk www.dancutter.com