



We keep it simple **without** **compromising**

We specialise in robotic systems for cutting, grinding,
and milling in all materials from PVC and liners to
concrete and steel.



CONTENTS

About Dancutter	03
We keep it simple without compromising	03
Fast, easy and simple	04
From problem to solution	04
Minicam Group	05
About Minicam Group	05
DC MINI BIKE	06
Highlights and technical data	06
Watch a video of the DC MINI BIKE	07
Cutting heads	08
DC SUPER FLEX	09
Highlights and technical data	09
Technical details	10
Watch a video of the DC SUPER FLEX	11
Cutting heads and accessories	12
Control unit and FPV headset	13
Centring toolset	14
Grabber	15
Hanging clamps and handles	16
Toolbox	17
DC MAXI FLEX	18
Highlights and technical data	18
Technical details	19
Watch a video of the DC MAXI FLEX	20
Cutting heads and accessories	21
Control unit and FPV headset	13
Centring toolset	14
Toolbox	22
Dancutter service centres	23

We keep it simple without compromising

DANCUTTER A/S



Dancutter A/S

Designing and manufacturing trenchless pipeline rehabilitation equipment for over 30 years. We specialise in robotic systems for cutting, grinding, and milling all materials from PVC and liners to concrete and steel.

From the beginning, Dancutter has been developing cutter solutions in cooperation with our customers. The feedback we receive in our daily work constitutes the core of our sustained efforts to develop simple and flexible cutters that operate in all types of materials.

We find solutions to even the most challenging projects, which is why our cutter systems are currently being used in more than 60 countries all over the world, primarily in the oil, gas, ventilation, rainwater, and waste-water industries.

Fast, easy, and simple

We at Dancutter are committed to offering cutting solutions that are fast, easy, and simple to operate, regardless of the size or type of pipe or diameter of cut that our customers need. Therefore, we build our cutters with advanced technology, high-performance materials, and advanced motors. In short, we strive to offer the best solutions for all cutting needs. Dancutter makes the job fast and easy for your workers and yourself, through our advanced tools designed for trenchless pipeline rehabilitation. Our customers trust us to deliver quality products that save them time, help them move through their workflows faster, and keep their businesses running smoothly.

The cutters from Dancutter provide the user with a flexible solution that can be quickly set up and operated by one person. Furthermore, these machines are quick, efficient, and cost-effective. They are designed for both vertical and horizontal pipe bends and have a wide range of sizing options, be it straight or corner-cutting, to ensure perfect results.

From problem to solution

The greatest challenge in sewer pipeline rehabilitation is to access the pipes without having to dig up the road or garden. In 1988 this led to the development of a prototype for the world's first cutter.

A robotic arm was fitted with a cutter head and skateboard wheels borrowed from the inventor's son. Dancutter was formed in 2002 and our expertise in branch pipe cutting was born from the inventor's practical experience and has been continuously refined since. Dancutter's goal is to deliver high-quality and innovative products for trenchless pipeline rehabilitation.

For more than twenty years, Dancutter has been a reputable global player in the field of pipe opening cutters. We have used our expertise to develop an advanced range of equipment that has been proven time and time again to get the job done quickly and safely. Today, our cutters are used to open new branch pipes and to maintain existing pipes in industrial and municipal applications, including drain cleaning and cutting of tree roots in water lines. Our products are sold through dealers with ample knowledge of their use and environment.

Dancutter's skilled employees continue to convert customer feedback and challenges from their everyday work into cutter solutions that strike a balance between technological finesse on the one hand and strength and user-friendliness on the other.



Dancutter is now part of a bigger family

MINICAM GROUP

About Minicam Group

The Minicam Group consists of several companies, each specialising in a specific set of solutions for pipeline inspection, maintenance and rehabilitation, co-operating with each other to offer the widest possible range of cutting, inspection and spray-lining solutions and services in the industry.



[More about Minicam Group](#)

Cutting



 **dancutter**

[More about Dancutter](#)

Inspection



 **minicam**

[More about Minicam](#)

Lining



 **sewertronics**

[More about Sewertronics](#)

Dancutter's smallest cutter

DC MINI BIKE

Fast, Easy, and Simple

DC MINI BIKE is Dancutter's smallest cutter. When you are cutting, grinding, and milling inside narrow pipes (50 - 75 mm / 2" in.) or in cramped spaces that are difficult to access DC MINI BIKE, is a powerful solution for small pipe cutting, no matter if the pipe is made of PVC, concrete, cast iron or steel. We also offer an extensive range of **cutting heads** for various purposes.

DC MINI BIKE is lightweight, flexible, and manoeuvrable, and the compact design of the cutter makes working at awkward angles easier while offering ergonomic flexibility and easy control.



Highlights

- ✓ Small, lightweight, and powerful
- ✓ Extremely flexible in 45° and 90° bends
- ✓ Cuts, mills, and grinds in all materials
- ✓ User friendly
- ✓ Precise control
- ✓ Toolbox standard accessory

Technical data

- ✓ Pipe diameter: 50 - 75 mm / 2" in
- ✓ DC MINI BIKE is operated using a bicycle-like handlebar, which gives the operator fine-tuned control over the cutter's movements. A lever on the handlebar activates the cutter's air grinder
- ✓ DC MINI BIKE is extremely flexible and easily manoeuvres through one 45° bend in a 50 mm / 2" in. pipe and through several 90° bends in a 75 mm / 3" in. diameter pipe
- ✓ DC MINI BIKE comes with a supply hose in your preferred length, from 1 to 15 meters (3' ft. 3" in. - 49' ft. 2,5" in.)

Dancutter's smallest cutter

DC MINI BIKE



[Watch a video of the DC MINI BIKE](#)

Cutting heads for

DC MINI BIKE

Carbide cutting heads

Premium cutting heads specially designed for milling and cutting in PVC and liner.

The cutting heads are hard and sturdy and the unique design and specialised manufacturing method with carbide flakes give the heads an excellent ability to "bite" into the material.

[See our range of different cutting heads](#)



Diamond cutting heads

Our premium diamond heads are specially designed for milling in concrete, cast iron, or stainless steel.

The cutting heads are hard and long-lasting with diamond segments placed on the heads for efficient concrete removal.

[See our range of different cutting heads](#)



Dancutter's extremely flexible cutter

DC SUPER FLEX

DC SUPER FLEX is Dancutter's extremely flexible cutter. It can move through several 90° bends in a 100 mm pipe and works effortlessly whether the pipe is straight or has bends. The flexibility of the DC SUPER FLEX makes it ideal for re-opening laterals, and its robustness and durability let it easily remove concrete or other hard deposits from pipelines.

When you are cutting, milling, and grinding in pipes from 75 – 150 mm / 3" - 6" in., DC SUPER FLEX is the perfect solution, no matter if the pipe is made of PVC, concrete, cast iron or steel. We have an extensive range of **cutting heads** for various purposes.



Highlights

- ✓ 360° continuous rotation
- ✓ Stainless steel
- ✓ 12" colour display
- ✓ Extremely flexible in 45° and 90° bends
- ✓ Cuts, grinds, and mills in all materials
- ✓ User friendly
- ✓ Precise control
- ✓ Toolbox and centring tool with brushes are standard accessories

Technical data

- ✓ Pipe diameter: 75 - 150 mm / 3" - 6" in
- ✓ DC SUPER FLEX can be operated by just one person using the control unit
- ✓ Control unit with 2 joysticks, a keypad with a 12" colour display. It features inlet and outlet sockets for connecting a video recorder, computer, external camera, or FPV headset
- ✓ The camera on the cutter has a spray nozzle that cleans the lens with air or washer fluid
- ✓ The DC SUPER FLEX comes with either a 25-metre or a 50-metre hose

Dancutter's extremely flexible cutter

DC SUPER FLEX

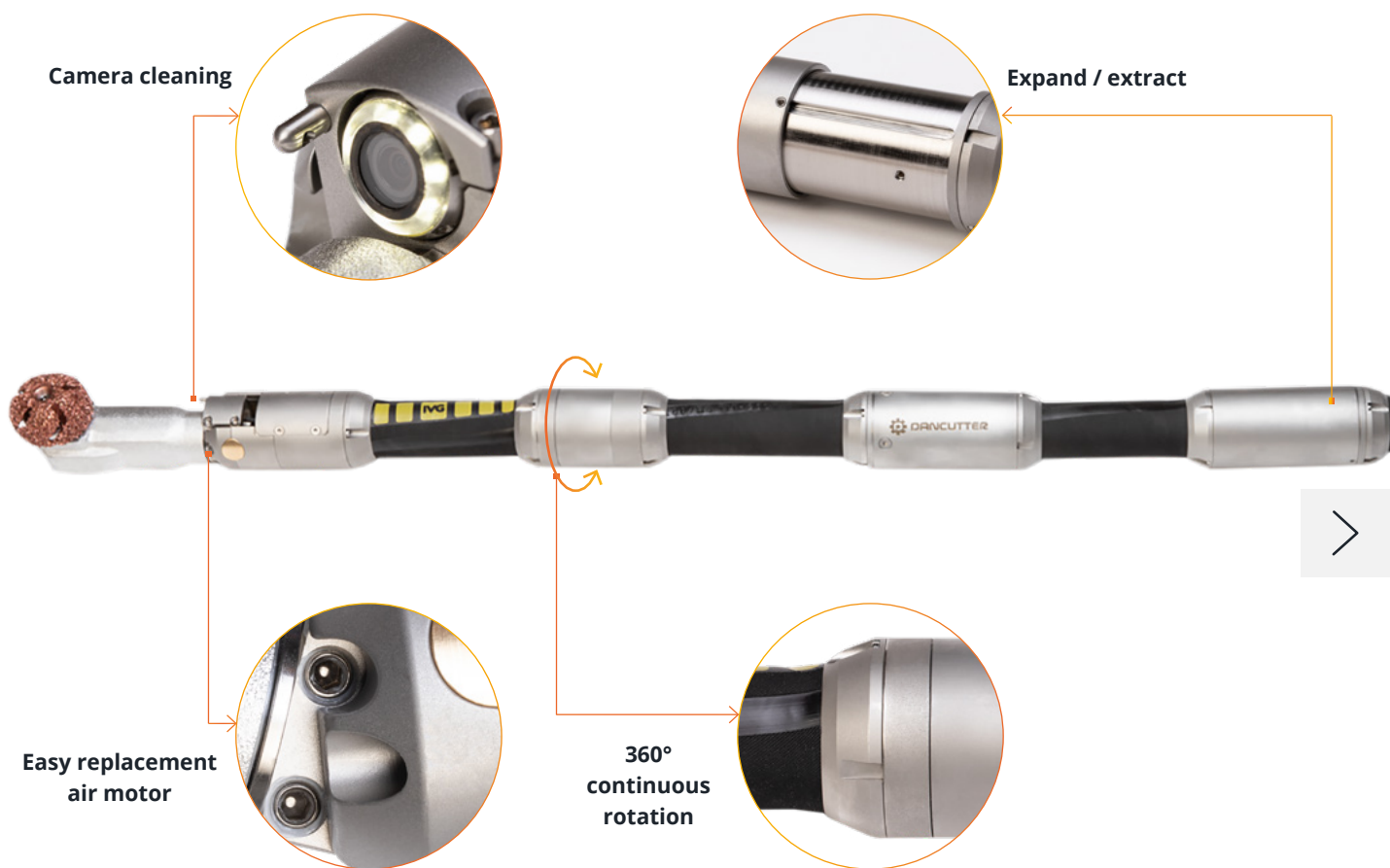

	PIPE DIMENSION	DIA. 75 - 150 MM, 3" - 6"		EXPANSION / EXTRACTION	60 MM - 2,4"
	SUPPLY HOSE	25 OR 50 METRES, 82 OR 164 FT		ROTATION	360° CONTINUOUS ROTATION
	FLEXIBLE	45° - 90°		GRINDS, MILLS AND CUTS	PVC, LINER, CONCRETE, IRON, CAST IRON, STAINLESS STEEL

Dancutter's extremely flexible cutter

DC SUPER FLEX



[Watch a video of the DC SUPER FLEX](#)

Cutting heads and accessories for **DC SUPER FLEX**

Carbide cutting heads

Premium cutting heads specially designed for milling and cutting in PVC and liner.

The cutting heads are hard and sturdy and the unique design and specialized manufacturing method with carbide flakes give the heads an excellent ability to "bite" into the material.

See our range of different cutting heads



Diamond cutting heads

Our premium diamond heads are specially designed for milling in concrete, cast iron, or stainless steel.

The cutting heads are hard and long-lasting with diamond segments placed on the heads for efficient concrete removal.

See our range of different cutting heads

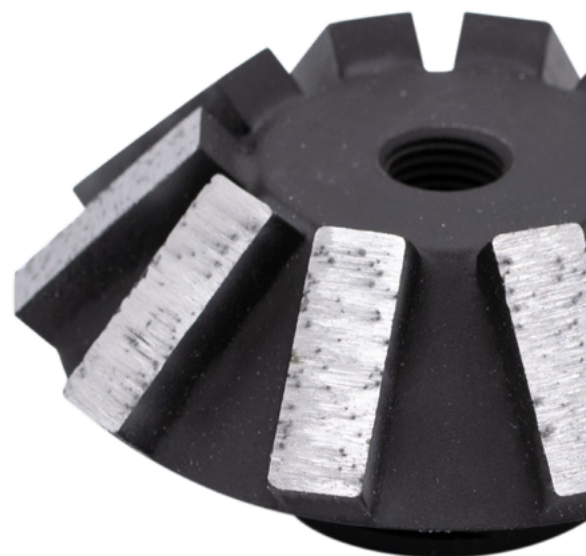

DC SUPER FLEX and DC MAXI FLEX

CONTROL UNIT

Smooth and effortless control of your cutter

DC SUPER FLEX and DC MAXI FLEX are operated with Dancutter’s control unit which has two joysticks. The joysticks provide smooth and effortless control of the cutting action, controlling the milling motor’s rotation and the movements of the cutter arm – raise, lower, expand and extract. You can also control the spray nozzle that cleans the camera with air or washing fluid.

The control unit is built into a heavy-duty case and a 12" colour screen in the control unit’s lid provides a sharp, precise image of the cutter’s position in the pipe. You can switch between images from the cutter’s camera and an external camera, and it is also possible to reverse the controls, so that it mirrors your movements.

The control unit also has input and output connectors for connecting an external camera, monitor or FPV headset.

Montér og styr DC SUPER FLEX fra cutterens ramme eller brug et forlænger-kabel (op til 15 meter), når du ønsker at stå eller sidde med kontrolenheden i afstand fra arbejdsstedet. Mount and control the DC SUPER FLEX on the cutter’s frame or use an extension cable (up to 15 meters) when you want to stand or sit with the control unit at a distance from the worksite.



DC SUPER FLEX and DC MAXI FLEX

FPV HEADSET

A first-person view of what your cutter camera sees inside the pipe

Dancutter’s FPV Headset is an essential accessory when you are cutting in bright sunlight with the DC SUPER FLEX or DC MAXI FLEX.

The high-quality headset has an ultra-immersive field up of view, an integrated 32-channel wireless receiver, built-in SD card support to 32 GB (AVI file), and USB charging.

With the headset, we have focused on usability first by letting the cutter operator enjoy the full FPV experience without worrying about extra charging cables or accessory components.

Included onboard DVR, uses an integrated channel scanner to pick up the strongest video feed, and has an improved 800 × 480 TFT resolution display for a crisper image. The onboard OSD shows video signal strength, battery lifetime, and selected channel.



DC SUPER FLEX

CENTRING TOOLSET

Allows for easy, frictionless movement and keeps your cutter centred in the pipe

Dancutter's Centring Toolset with Wheels is an expert assistant to help you maintain the precision of your DC SUPER FLEX. Mounting this optional accessory on your cutter ensures that it stays centered inside the pipe, resulting in cleaner and faster cuts and equal precision all the way around.

Constructed to meet Dancutter's high standards of flexibility and user-friendliness the centring toolset offers some unique features: a rotating centring ring with a brass slide bushing that ensures unimpeded operation with 360° continuous rotation. The wheels on the centring toolset make it easy to push the cutter out to remote locations in a pipe system.

The centring toolset with wheels is especially recommended for use when operating the DC SUPER FLEX in 150 mm / 6" pipes.



Centring Toolset with Wheels
150 mm / 6" in pipes

DC SUPER FLEX

GRABBER

A great no-dig tool

The Dancutter Grabber is a great no-dig tool for removing obstacles stuck inside sewer pipes - a tree root, beer can, chain knocker or other tools lodged inside a pipe can slow down the work or worst case require digging up the pipe.

The Dancutter Grabber is an add-on to the DC SUPER FLEX and can be opened and closed with the grinder switch on the control unit. Powerful gripping teeth on the grabber jaws effectively hold on to the object while you pull it out, and the Grabber moves effortlessly through 45° and 90° bends in 4" - 6" in / 100 - 150 mm or larger pipes.



Highlights

- ✓ Extremely flexible in 45° and 90° bends
- ✓ 360° continuous rotation
- ✓ Stainless steel
- ✓ User friendly
- ✓ Easy to mount on the DC SUPER FLEX
- ✓ Precise control

Technical data

- ✓ Pipe diameter 75 - 150 mm / 3" - 6" in
- ✓ Air-driven
- ✓ Grabbing diameter: 68 mm / 2,7 in

DC SUPER FLEX

HANGING CLAMPS

Provide easy handling when working in vertical pipes

The Dancutter hanging clamps are designed for mounting on the DC SUPER FLEX and provide easy handling when working in vertical pipes. With the hanging clamps attached to the yellow hose, the weight of the cutter is supported by a powerful steel wire, instead of being carried by the hose.

This accessory will reduce the risk of damage to the cutter hose because you avoid putting excessive strain on it when raising and lowering the cutter. The hanging clamps with steel wire allow the weight of the cutter to be carried by hand or attached to a strap on a winch.



DC SUPER FLEX

HANDLES

An easier way to move the DC SUPER FLEX around

We have developed an easier way to move the DC SUPER FLEX around the worksite. This set of quick attach handles can be mounted on the cutter frame and allows for effortless transport even on a bumpy road.

The stainless-steel handles are fitted with ergonomically designed rubber handles that give the cutter operator better control and increased comfort.

DC SUPER FLEX

TOOLBOX

Toolbox Standard - DC SUPER FLEX

Extension, Centring tool set with brushes, Pneumatic oil, Carbide cutting head 37 × 16 mm, Pin for DK3713-16, Special tool for DK3713-B, Washer Ø10, Nut 3/8 UNF, Elastic washer Ø10 mm, Bolt extension 16 mm, Bolt extension 22 mm, Bolt extension 32 mm, O-ring 10 × 2,4 mm, Screw M 3 × 6, Pointed screw M 6 × 10, Grease for the Air Motor, Allen key set, Wrench for Air Motor AG50, Insert, Toolbox, Wheel Nut Flange, Extension for arm.

See Toolbox Standard

Standard



Toolbox Gold Upgrade - DC SUPER FLEX

Grabber, Extension cable 6M, Centring tool w./wheel, Carbide cutting head 26 × 29 mm, Carbide cutting head 30 × 15 mm, Carbide cutting head 37 × 13 mm, Carbide cutting head 46 × 23 mm, Diamond ball head 36 × 37 mm, Diamond head 30 × 15 mm, Diamond head 53 × 26 mm, Cutting disc 50 × 10 mm, Pin for DD9008, Cutting disc 65 × 1,1 mm, Cutter head Holder Short - 3/8 UNF, O-ring 10 × 2,4 mm, Screw M3 × 6, Pointed screw M6 × 10, Wheel Holder Flange, Bolt extension 16 mm, Bolt extension 22 mm, Bolt extension 32 mm, Air Motor G38, Wheel Holder Flange, Allen Head Plug.

See Toolbox Gold Upgrade

Gold Upgrade



Dancutter's most powerful cutter

DC MAXI FLEX

DC MAXI FLEX is Dancutter's most powerful cutter. It has an extremely powerful motor which makes the cutter both fast and efficient. The DC MAXI FLEX is flexible and can go through several 45° bends in a 150 mm pipe and works effortlessly whether the pipe is straight or has bends.

If you are mostly working in larger pipes, DC MAXI FLEX is your right choice for reopening laterals or removing hard deposits like concrete. When you are cutting, milling, and grinding in pipes from 100 - 300 mm / 4" - 12", DC MAXI FLEX is a powerful solution whether the pipe is made of PVC, concrete, cast iron, or steel. We also offer an extensive range of **cutting heads** for various purposes.

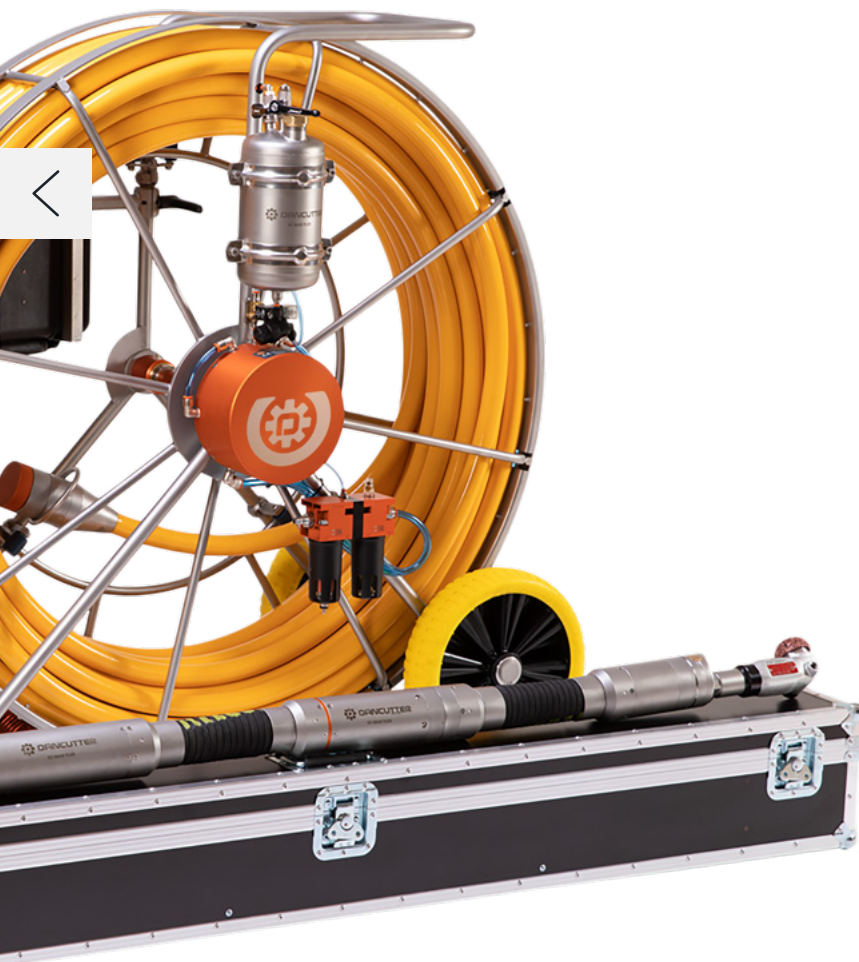

Highlights



- ✓ Extremely powerful motor
- ✓ 360° continuous rotation
- ✓ Stainless steel
- ✓ 12" colour display
- ✓ Flexible through several 45° bends
- ✓ Cuts, grinds, and mills in all materials
- ✓ User friendly
- ✓ Precise control
- ✓ Toolbox, centring tool with brushes, and transport box are standard accessories

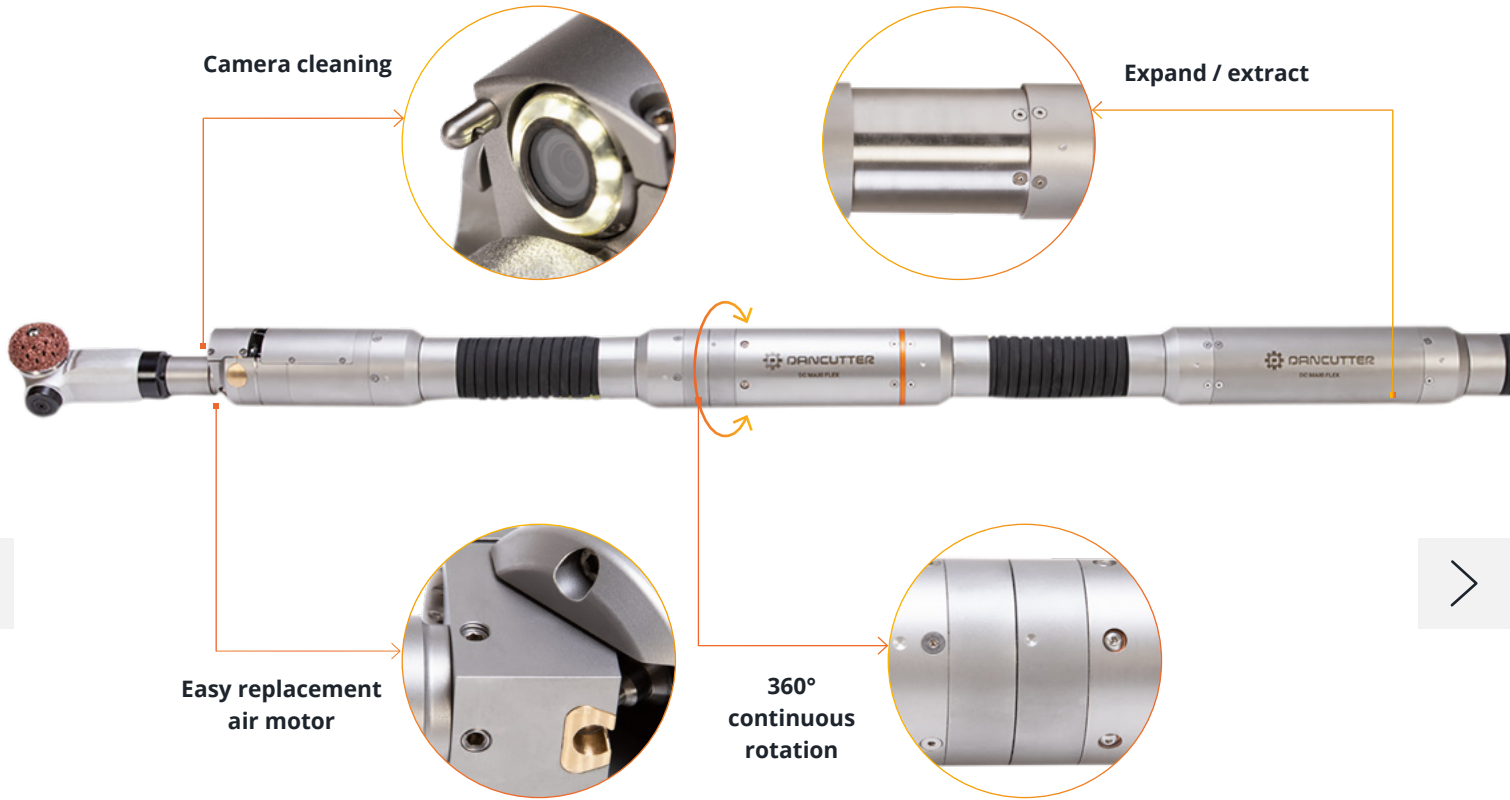

Technical data

- ✓ Pipe diameter: 100 - up to 400 mm / 4" - 16" (with centring tool set)
- ✓ DC MAXI FLEX can be operated by just one person using the control unit
- ✓ Control unit with 2 joysticks, a keypad with a 12" colour display. It features inlet and outlet sockets for connecting a video recorder, computer, external camera, or FPV headset
- ✓ The camera on the cutter has a spray nozzle that cleans the lens with air or washer fluid
- ✓ The DC MAXI FLEX comes with a 70-metre hose

Dancutter's most powerful cutter
DC MAXI FLEX



	PIPE DIMENSION	DIA. 100 - 400 MM, 4" - 16"
	SUPPLY HOSE	70 METRES, 230 FT
	FLEXIBLE	FLEXIBLE 45° IN A 150 MM, 6" PIPE

	EXPANSION / EXTRACTION	150 MM - 6"
	ROTATION	360° CONTINUOUS ROTATION
	GRINDS, MILLS AND CUTTS	PVC, LINER, CONCRETE, IRON, CAST IRON, STAINLESS STEEL

Dancutter's most powerful cutter

DC MAXI FLEX



[Watch a video of the DC MAXI FLEX](#)

Cutting heads and accessories for DC MAXI FLEX

Carbide cutting heads

Premium cutting heads specially designed for milling and cutting in PVC and liner.

The cutting heads are hard and sturdy and the unique design and specialised manufacturing method with carbide flakes give the heads an excellent ability to "bite" into the material.

[See our range of different cutting heads](#)



Diamond cutting heads

Our premium diamond heads are specially designed for milling in concrete, cast iron, or stainless steel.

The cutting heads are hard and long-lasting with diamond segments placed on the heads for efficient concrete removal.

[See our range of different cutting heads](#)



DC MAXI FLEX

TOOLBOX

Toolbox Standard - DC MAXI FLEX

Centring tool w/wheels, Extension, Adaptorbolt 27 × 33,5 M 8, Adaptorbolt 27 × 54 M 8, Adaptorbolt 27 × 85 M 8, Washer, Ø 10 mm, Nut, 3/8 UNF, Elastic washer, Ø 10 mm, O-ring 19 x 3 mm, Pointed screw M 8 × 12, Grease, Ring crescent wrench 27 mm, Allen key set, Wrench for Air Motor, UAG50, Insert, Toolbox, Pneumatic oil.

See Toolbox Standard

Standard



Toolbox Gold Upgrade - DC MAXI FLEX

Carbide cutting head 50 × 25 mm, Diamond head 46 × 47mm, Diamond head 70 mm, Axial, Diamond head 75 mm, Bolt for DD9025, Cutting disc 70 × 10 mm, Air motor AG100, Air motor UG65, Extension cable 6M, Wrench for Air motor UG65, Wrench for AG 100

See Toolbox Gold Upgrade

Gold Upgrade



Dancutter

SERVICE CENTRES

We believe that excellent service is essential

The Dancutter Service Team and our distributors ensure a high level of service and efficient maintenance of your Dancutter systems.

We provide a global service organisation that meets the needs of our customers all over the world through highly professional technical services, including fast and efficient support in case of urgent needs. With Dancutter as your service partner, you are guaranteed continuous technical services and support, maintenance and repair services, high-quality accessories, spare parts, and tailormade toolboxes to ensure maximum uptime of your equipment.

With us by your side, you can focus on achieving maximum productivity from your investment rather than worrying about managing its operation.

Find your closest Dancutter service centre





We will **be happy to answer**
any questions you may have...

Call
+ 45 96 51 21 50

Email
info@dancutter.dk

Web
dancutter.com

